

Cross Cutting Technologies in Renewables -- Grid Connected Renewables, Grid Control through Inverters and other High Speed Power Electronics

Dr. Leo Casey, EVP & CTO, Satcon Technology
Leo.casey@satcon.com



BUILDING ENERGY 11

CONFERENCE + TRADE SHOW FOR RENEWABLE
ENERGY AND GREEN BUILDING PROFESSIONALS

MARCH 8-10, 2011
SEAPORT WORLD TRADE CENTER BOSTON, MA

Faster, Smarter, Controllable, Greener, Distributed, Grid

the Key is?

-Power Electronics-



Satcon



Our Alternative Energy Journey

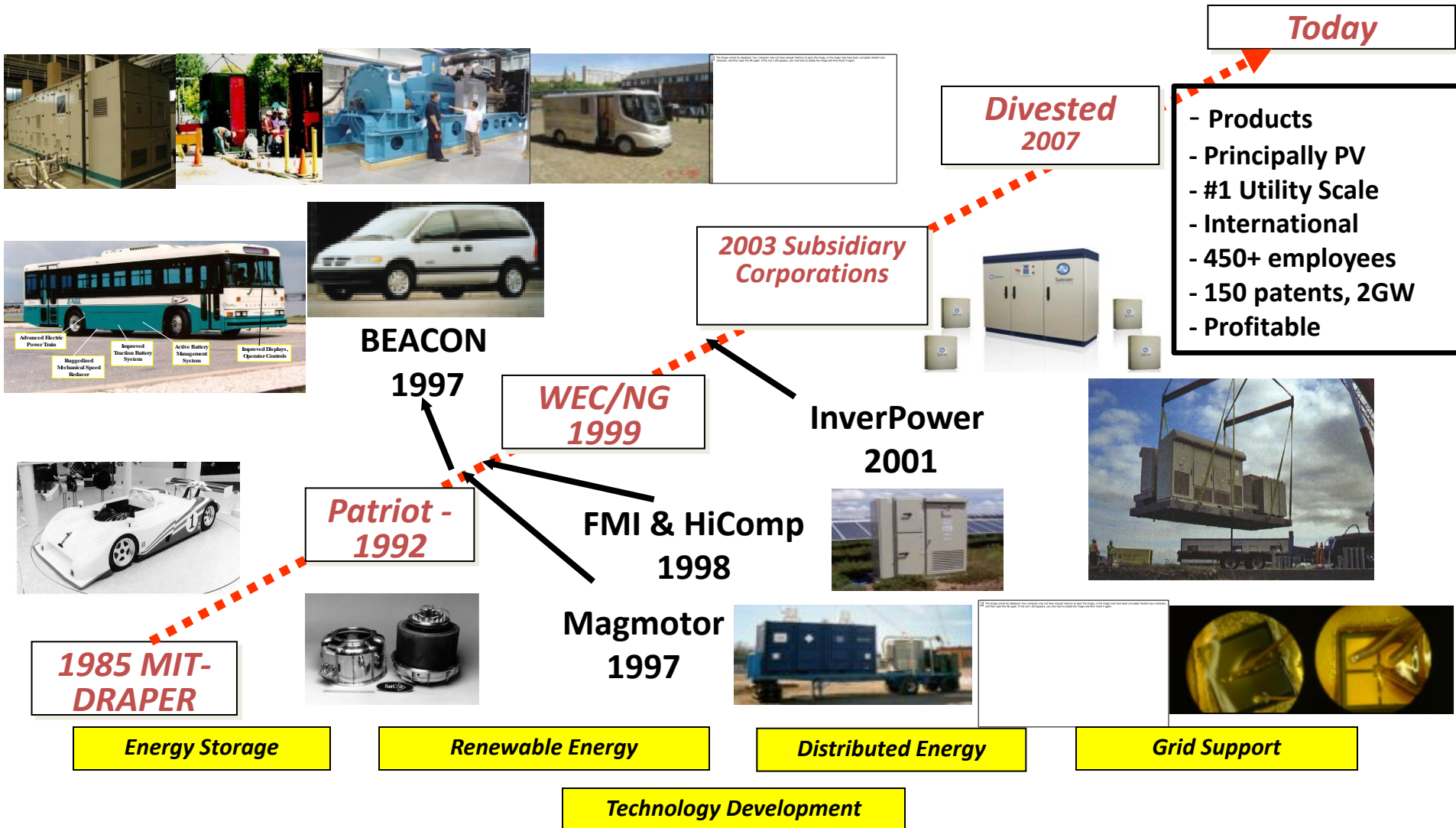

Presentation Overview

- Quick Review of Cost, Trends and Opportunities in Solar PV (\$/watt ?, SunShot ?)
- Role of electronics within that Solar PV context
- Grid issues (background to smartGrid and context of renewable integration, problem or solution ?)
- Synthesis of Power Electronics, Controls and Renewables to lead the way in terms of costs, intermittency, controllability and adoption

Overview

Grid – backbone of 150 years of industrialization, BUT aging infrastructure, designed for electromechanical devices, increasing penetration of renewables, slow centralized controls, needs transformation

Vision – Faster, Smarter interfaces, coordinated local and central controls at different time scales

Overcoming Technical Obstacles – Controllable, Distributed, Renewables thru Electronics

Electromechanics vs Electronics – Speed vs Overload capability, outlook positive for Electronics

Storage – The holy grail, but, how essential and on what time scales?

Costs, options, other electronic devices?

The US Grid

Eastern Interconnect-- “the World’s Biggest Machine”
925,000,000 hp - 2,000,000 sq mi -- 3600rpm

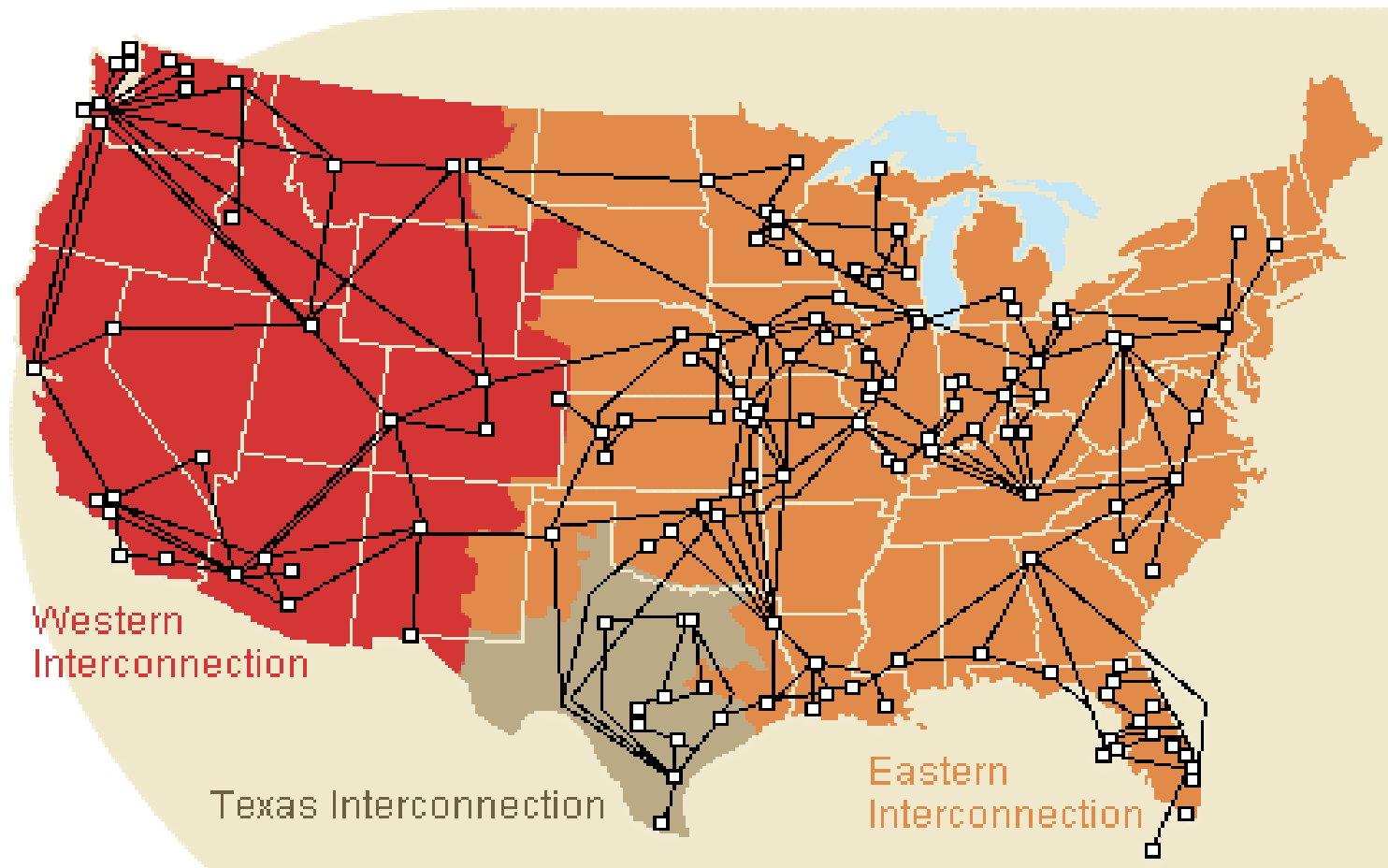

Electric Power – More Electric Future

- Dominant **secondary** source of energy
- Grid is a **BEAUTIFUL** thing
 - Instantaneous energy
 - ac
 - Rugged generators
 - Spinning “reserve”
 - Excess capacity (>15% is critical)
SIZED FOR 20%+
 - Low Impedance
 - Fault clearance
 - Overload
- Beautiful, but
 - no significant energy storage
 - Supply must equal demand
 - generator power angle
 - minimal local control
 - Time constraints of protective devices
- Importance of storage (some storage)
 - Distribution (remoteness of generation and utilization)
 - Load leveling (excess capacity), energy arbitrage
 - Power Quality (4-5 9's vs 5-6+ in EU)
 - Intermittent Renewables (**WIND**)

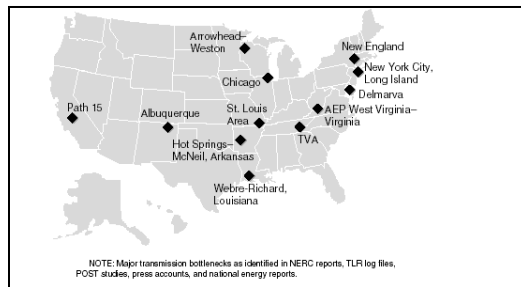

Electricity Infrastructure

Transmission SCADA control points	12
FERC grid monitor/control	20
Network Reliability Coordinating Centers	130
Regional Transmission Control Centers	>300
Utility control centers	10,500
Power plants	500
Large (>500 MW)	10,000
Small (<500 MW)	680,000 miles
Transmission Lines	7,000
Transmission substations	2.5 million miles
Local distribution lines	100,000
Local distribution substations	

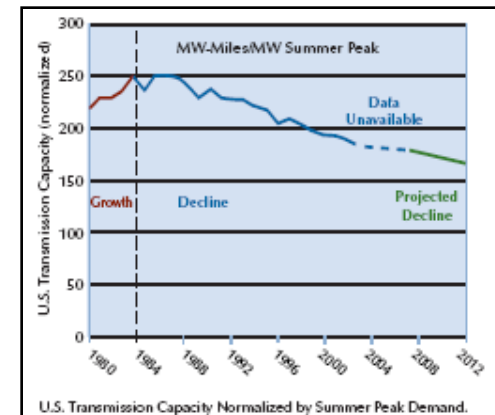

Modern Grid Issues

- An age of Increasing Electrification (~1TW capacity in EI),
 - BUT
 - Energy sources problematic (climate, security!)
 - Grid Power Quality is inadequate to electronic age (many aspects to this)
 - Slow and Archaic Electromechanical Hardware & Controls
 - Congestion in T&D infrastructure
 - NIMBY etc
 - **SOME ANSWERS**
 - Demand Response (time scale?)
 - Efficiencies
 - Renewables
 - Hi-Speed Controls
 - Hi-Speed Devices
 - Reconfiguration
 - DC transmission
 - TO **SOME PROBLEMS**

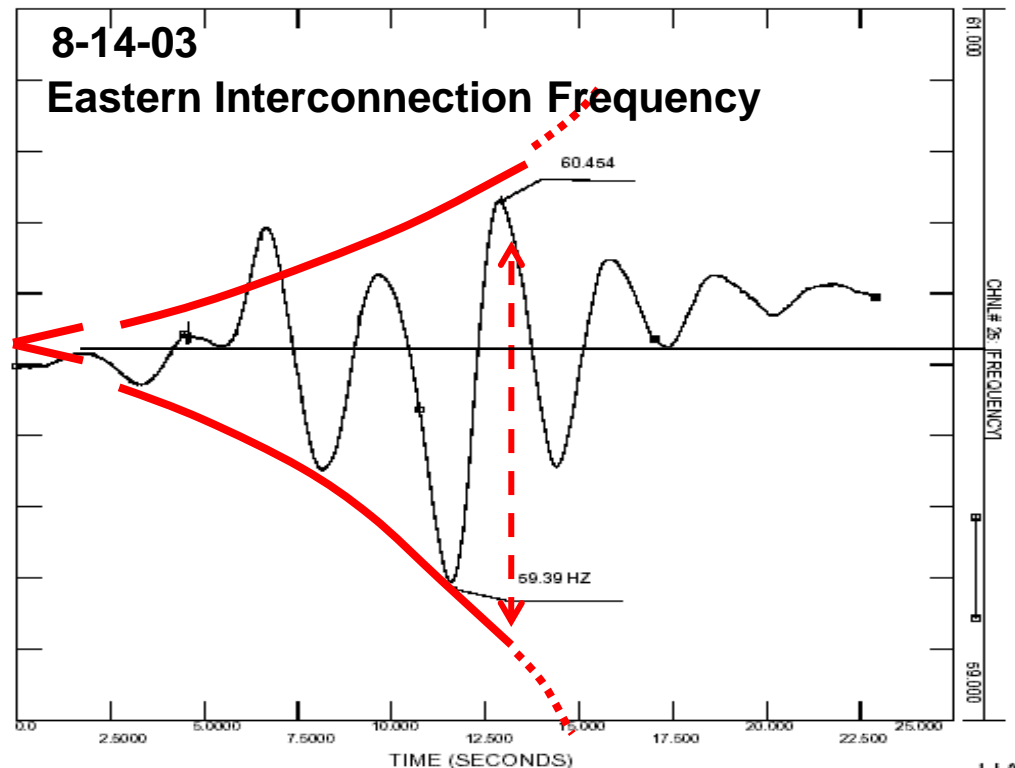

Modern Grid Issues

Utility Concerns About The Impact Of High Penetration DG on MV Feeders

- Fluctuating real power output from renewable sources
 - Increased switching operations for line regulators, tap changers, capacitors
 - Flicker due to fluctuating voltage
 - Transient voltage on sudden trip of DG station
- Effect of new generation and reversible power flow
 - Protective relay settings and operation
 - Conductor and equipment loading
 - Islanding of DG with residual load connected
 - Auto-reclosing feeder breaker onto energized DG

Generation Connected thru Electronics can be Transformative – BUT different Paradigm

- Readily Controllable (remotely)
- Supply Real Power, P, Dynamically
- Reactive power, Q, ($|P + jQ| < S_{INV}$), Dynamically
- Active Damping (stabilizing)
- Controllable or Synthetic Inertia
- Fault Clearing
- Rapid Dynamics
- Unbalanced
- Non-linear sourcing
- Active Filtering
- Harmonic cancellation

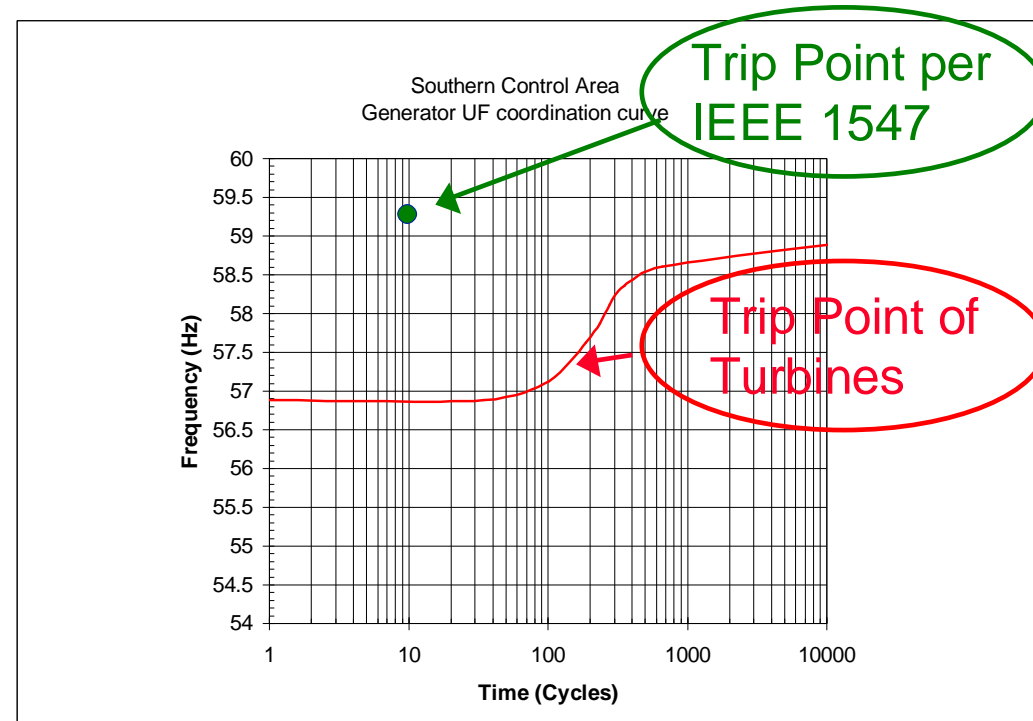

- Also, high speed series devices would
Limit faults and enable robust interactive microgrids

A Future Grid Vision

- Faster Protection & Control
- More robust
- More renewable
- More efficient
- More DC systems
- **More Electronics**
IN ALL LAYERS
- Higher PQ
- More μ Grids
 - Improved CF
 - More distributed
 - Reconfigurable
 - Faster Recovery

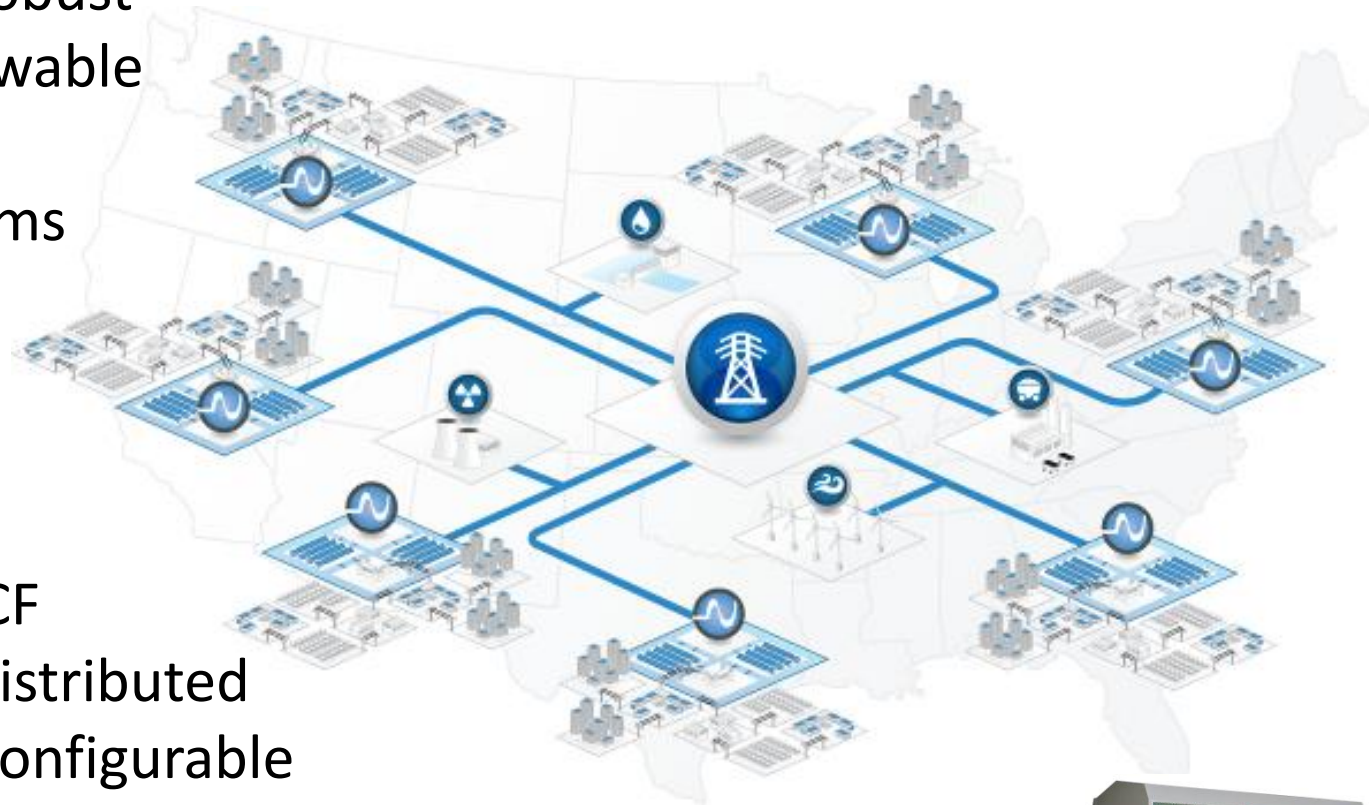

Power Electronics are Grid Ready

One Game Changer

Back to Back DC links with Mandatory
Sub-second Area Balance

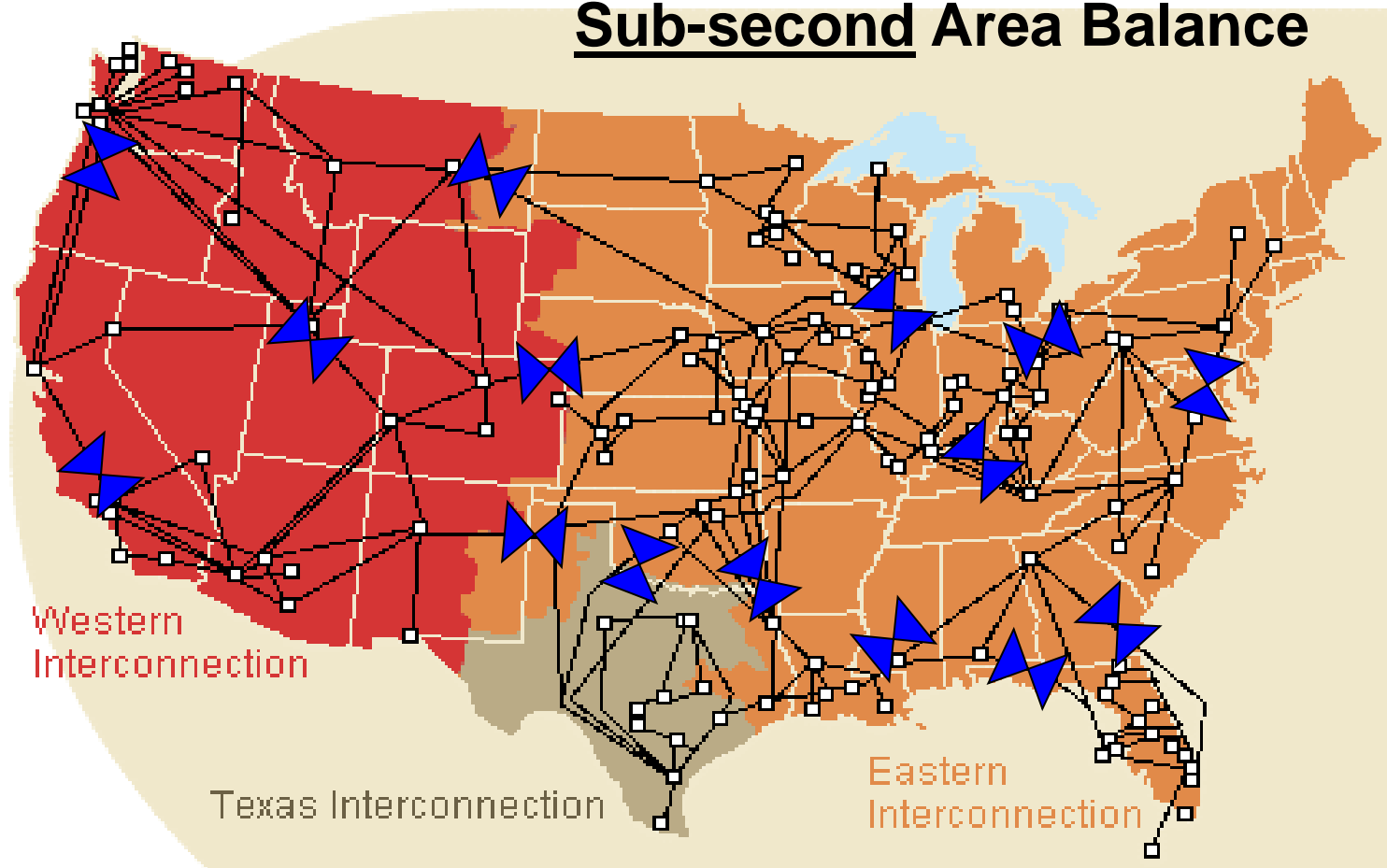

Barriers to High Penetration of Renewables

1. Cost (30+% drop in Utility scale solar PV in last 18 months)

- Panels
- Inverters, BOS
- O&M

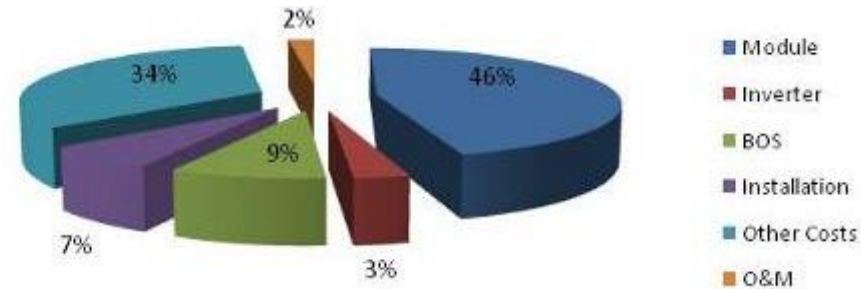

2. Controllability

3. Intermittency (Variability/Capacity Factor/Capacity Value)

4. Utility Industry Acceptance/Adoption

- Scale
- Performance
- Standards
- Familiarity (interconnect studies, protection studies)

Increasing Penetration of Renewables - examples

Denmark

- 18% of Electrical Energy
- New Control Regs.
- European Grid
- Curtailment

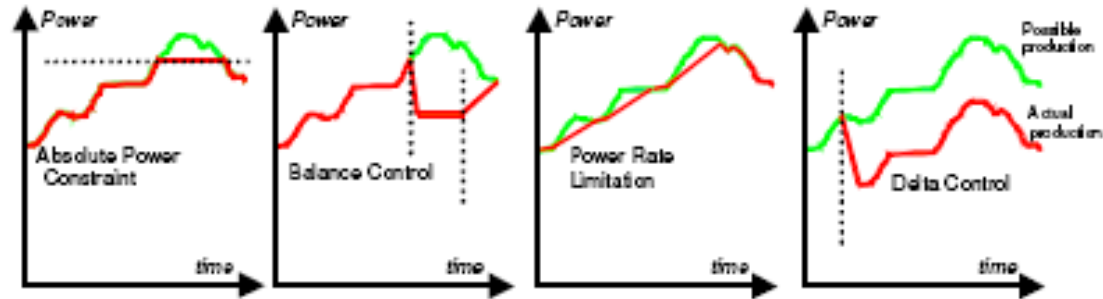

New Zealand

- 80% + renewables
- Hydro, geothermal, wind

Lanai

- 20% PV in diesel grid
- no storage but heavily curtailed
- 30% of peak with storage (coming)
- Ramp rates, curtailment, remote control, site controller, VARs, ride-thru

Studies, NREL east and west, 10-30%, no storage, ramp Coal
EU15, DisPower Study, 15-35%

Satcon Solstice Inverter Incorporates SEGIS Grid-Smart Control Features

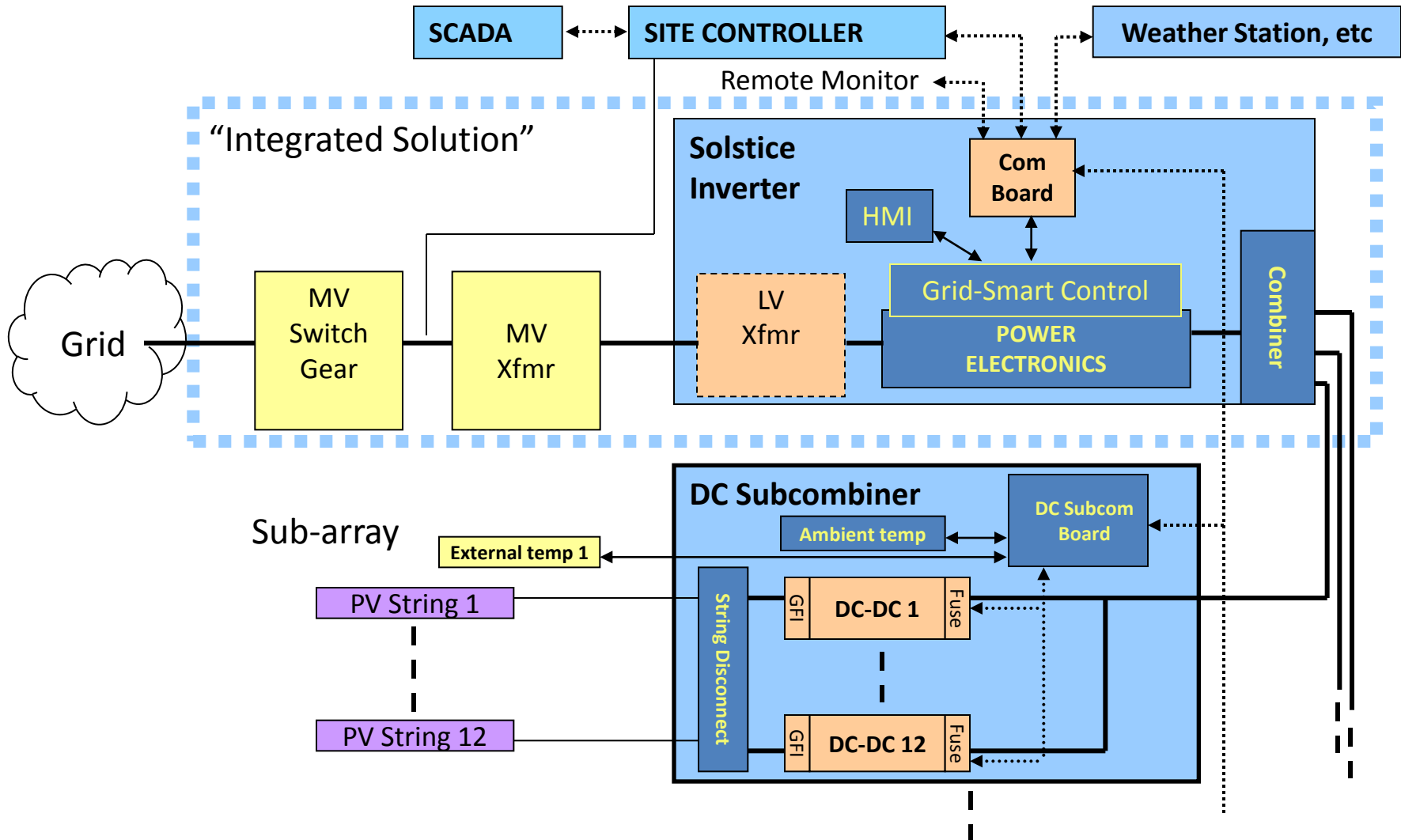

Low Voltage Ride Through

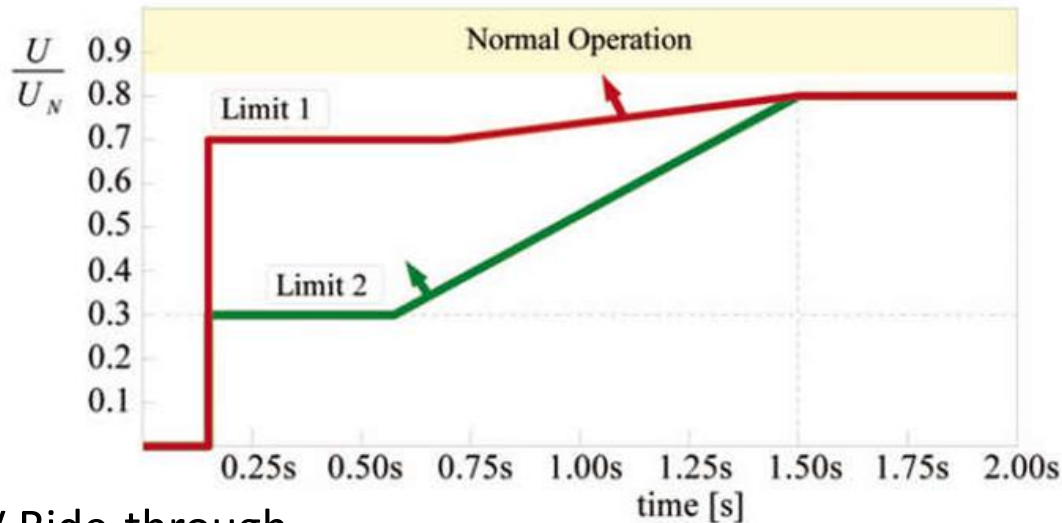

- Extended LV Ride-through
 - Ride-through more extensive voltage and frequency disturbances
 - Standard DER installations shut down when they are most needed – during voltage and frequency fluctuations
 - Shutting down generation such as DER inverters can make the disturbance worse
 - But ridethrough violates UL 1741 voltage and frequency limits, can violate anti-islanding rules
 - Fast DER inverter response can provide better support than other grid resources (tap changers, switched capacitors, load shedding, etc.)
 - European electricity associations such as BDEW, have already adopted extended ridethrough requirements
 - Grid voltages down to 0%, transients lasting up to 1.5 seconds

Illustration of Some Advanced Grid Support Control Features

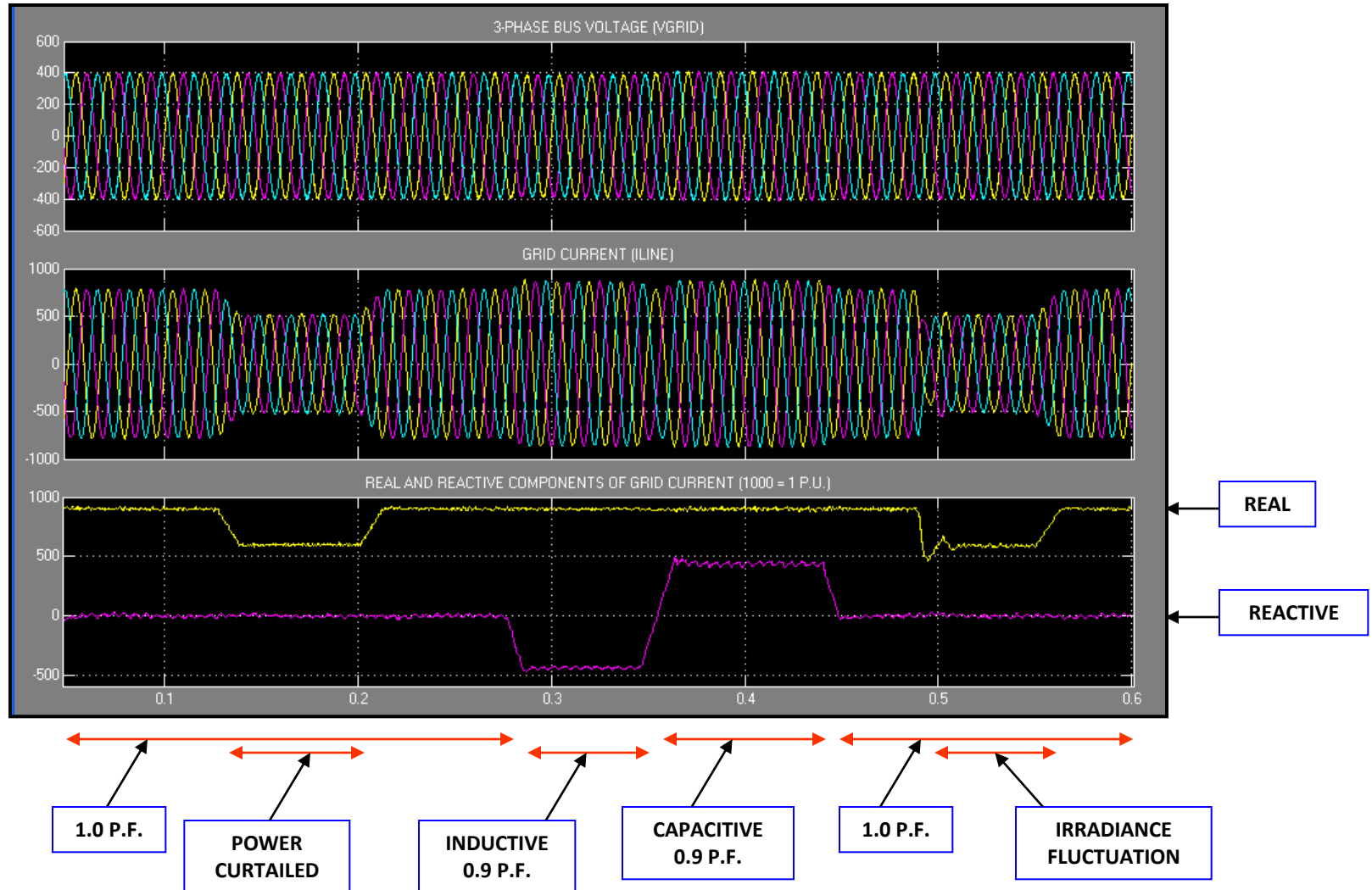

Satcon Solstice Two-Stage Architecture Facilitates Connection of DC Energy Storage

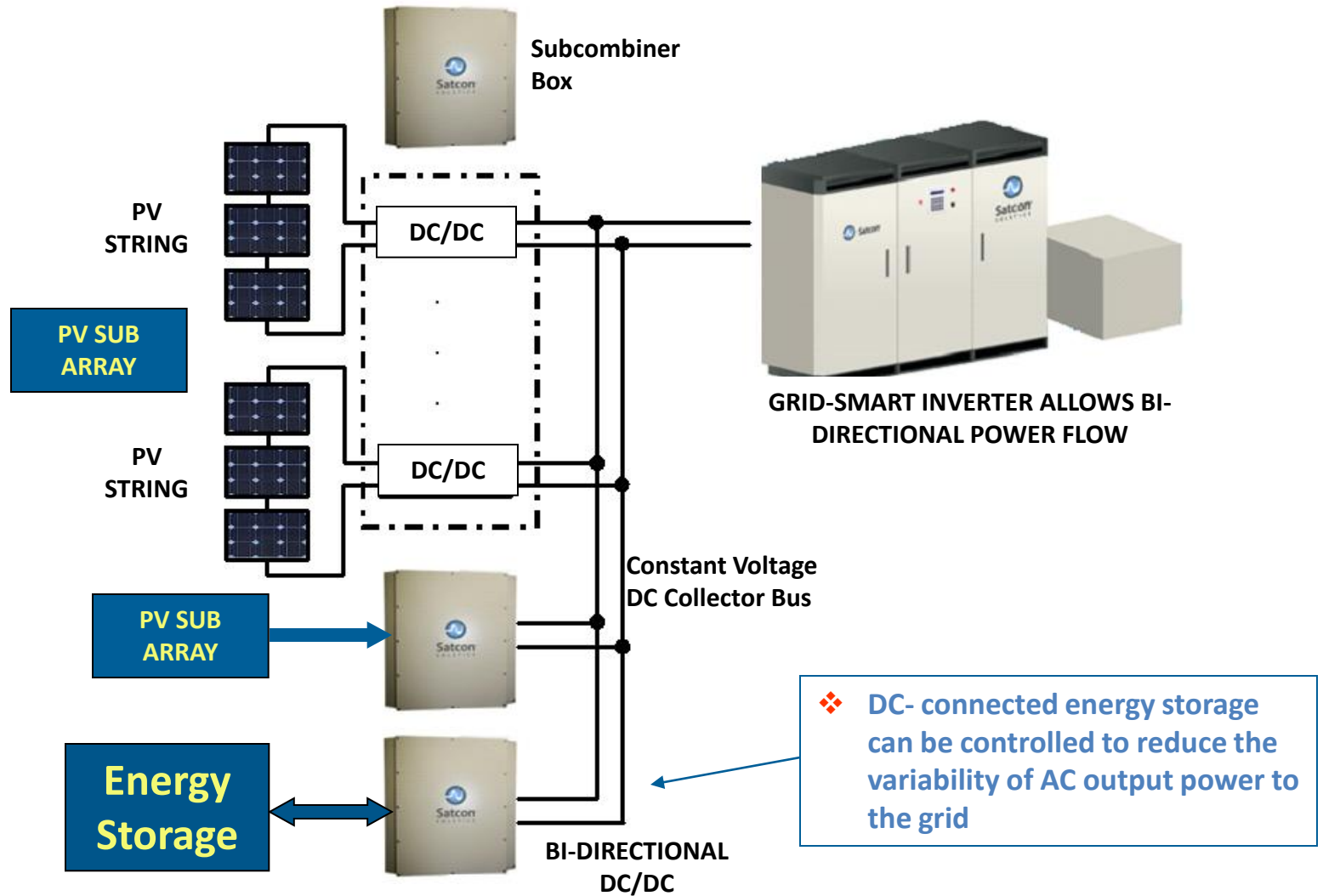

Site Controller Provides Real And Reactive Power Management At the Point Of Common Coupling

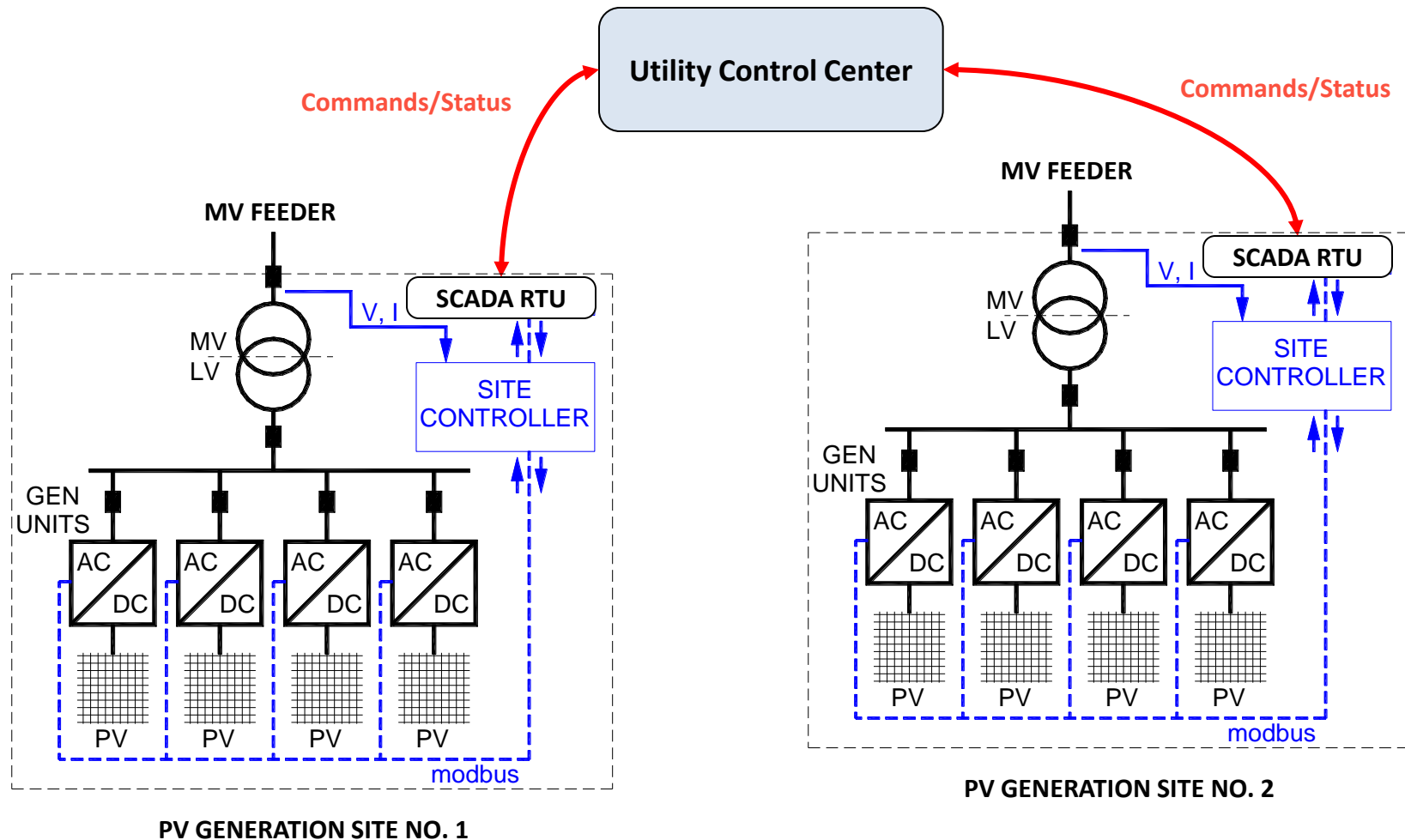

Intermittency (storage?)

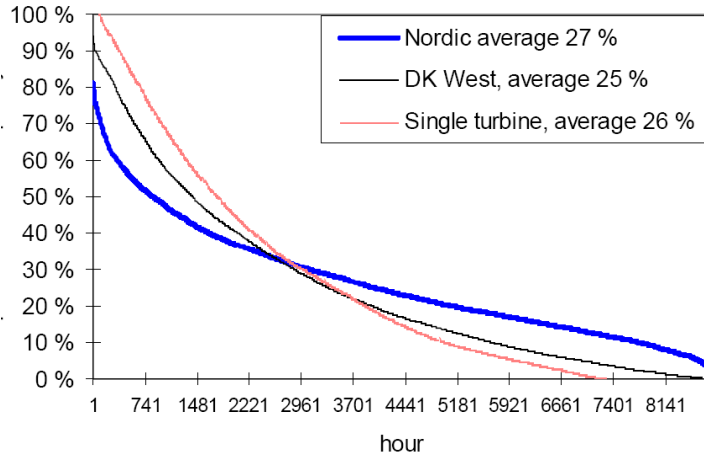

Averaging

-in space

-in time

Works. Transmission connected renewables utilize this. But what of local effects? Voltage change due to sudden power change on distribution feeder

Weapons against local effects of Intermittency

- Maintain real power with storage
- Forecasting
- Measurement coupled with ramping and regulation (auto)
- Ramp rates (ramp rate control using storage)
- Fast VARS
- Hybrid power plants
- Curtailment of renewable (or other)

2009 U.S. Electricity Generation by Source

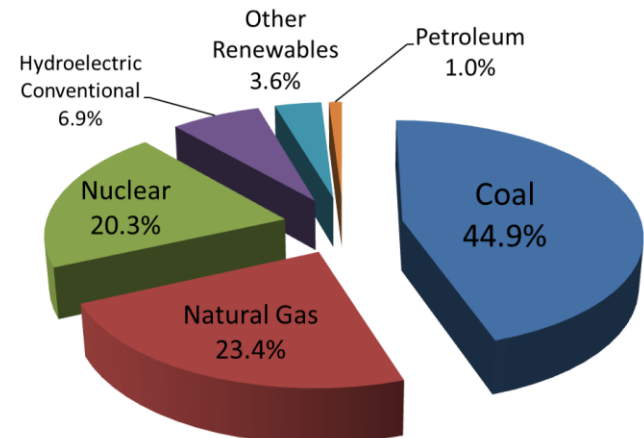

Real Power Output From PV Generating Station Fluctuates Due To Passing Cloud Cover

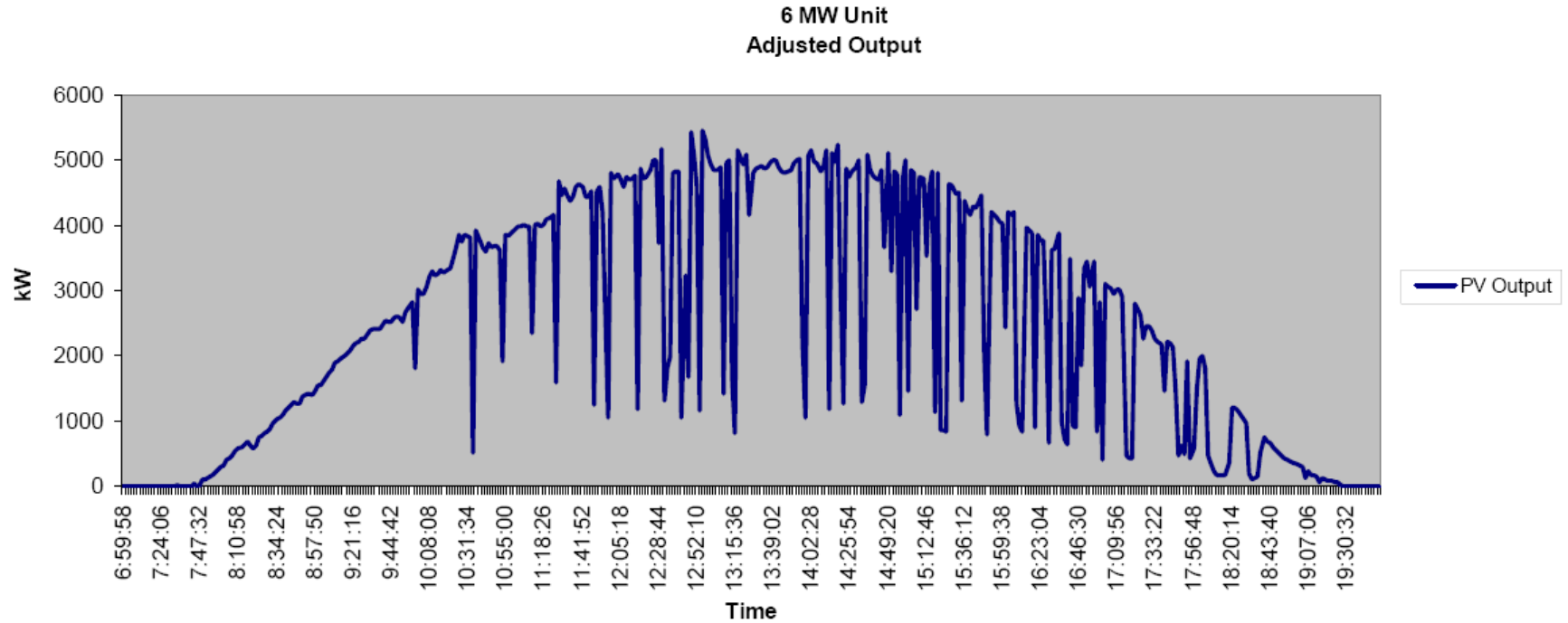

PV Inverter Simulation Shows Fast VAR Step Response Capability And The Effect On Local Bus Voltage

➤ Feeder X = 0.1 p.u. on inverter base

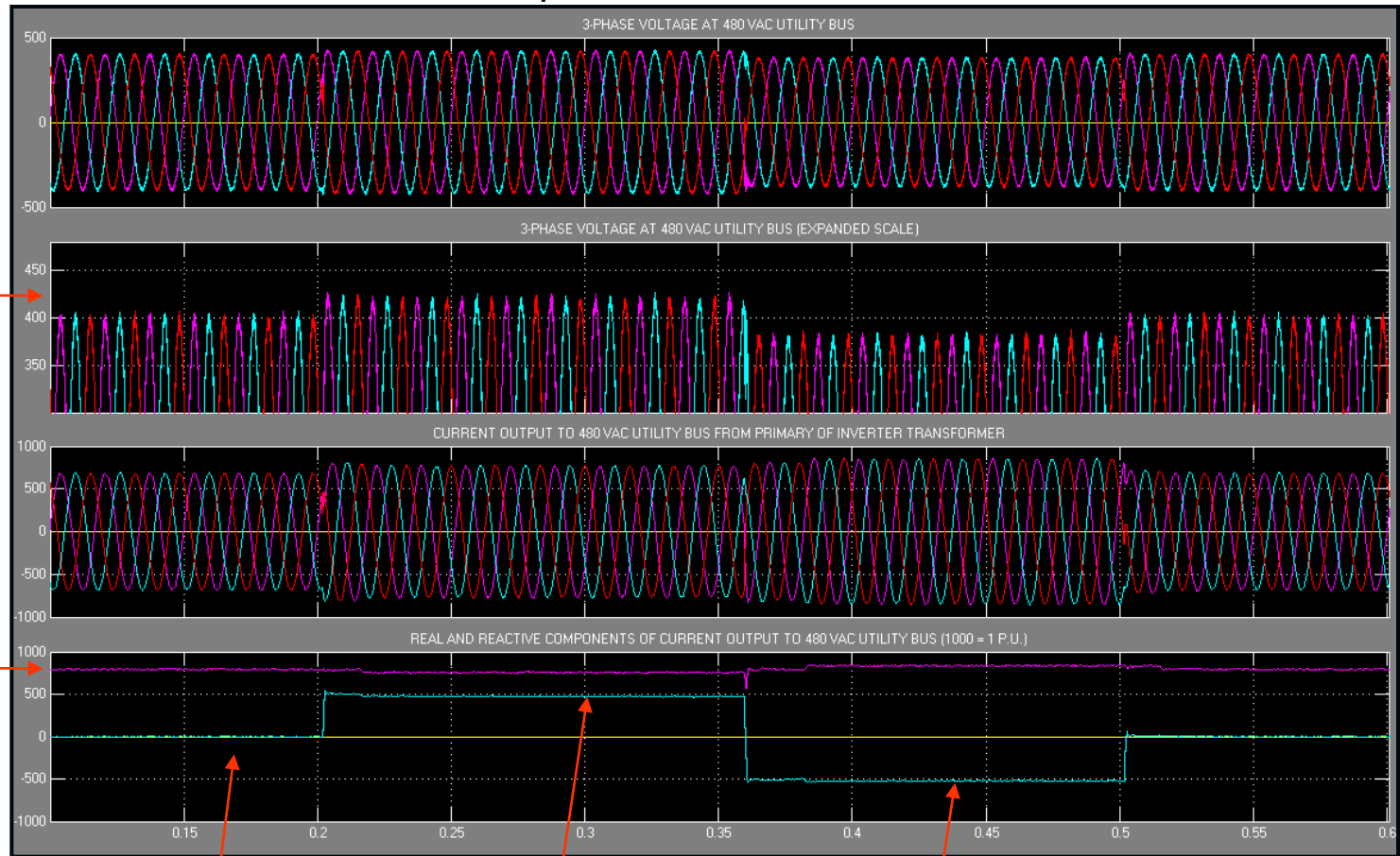

AC voltage variation +/- 5% approx.

Real power output = 0.8 p.u.

Reactive power output = 0 p.u.

Reactive power output = 0.5 p.u.

Reactive power output = -0.5 p.u.

Illustration Of Automatic Voltage Control On a Long 13.8 kV, 10 MVA Feeder With 5 MVA PV Plant Connected

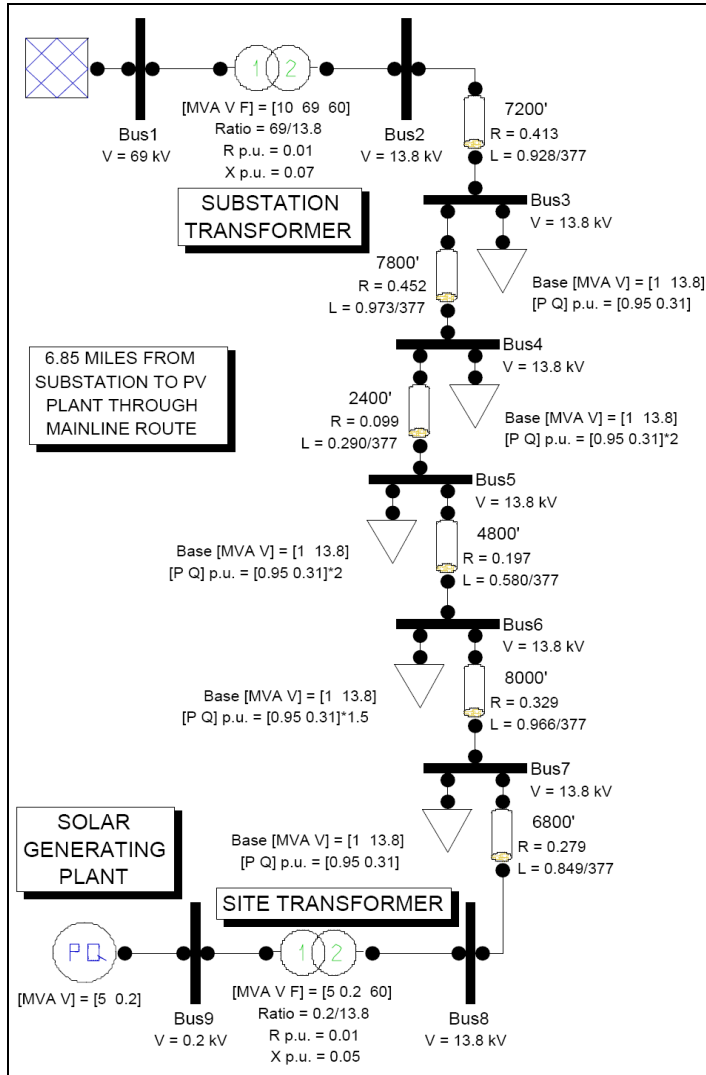

- No tap changers, line regulators, or capacitors
- Balanced feeder, balanced three-phase loads
- 9 buses - 7.5 MVA 0.95 p.f. constant power loads
- PV plant output, P = 4 MW

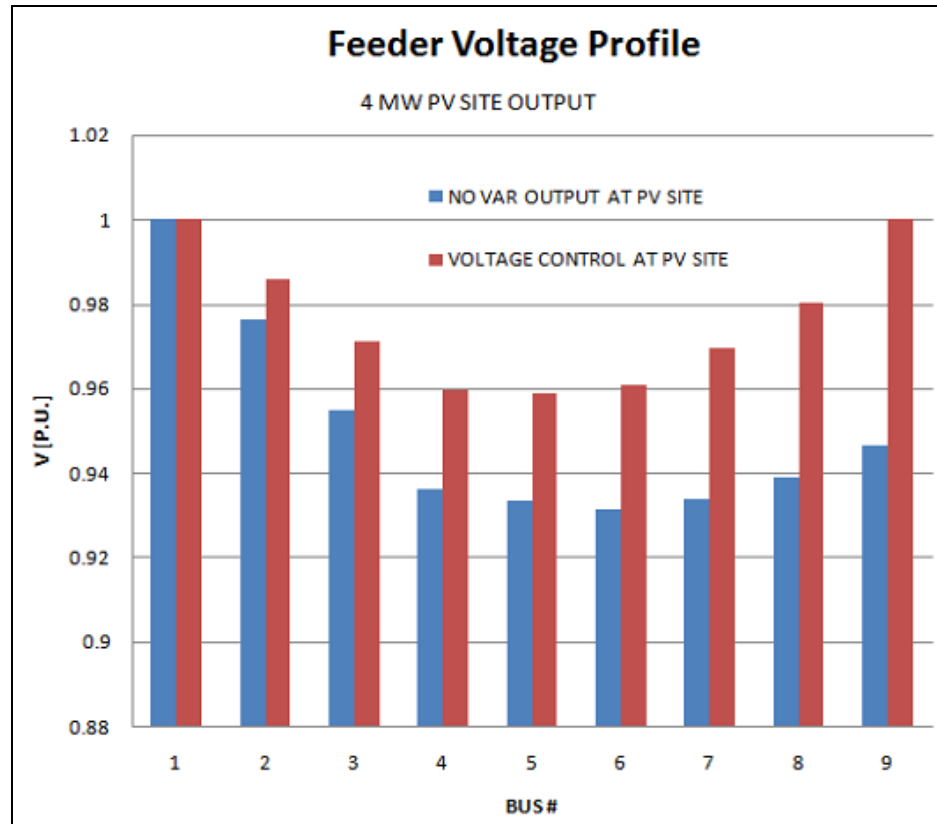

Flicker Assessed From Transient Simulation Data

- Short term flicker assessed from simulated voltage at Bus #7
- Post-processed through IEC Flickermeter
- Event repeated continuously for ten minutes

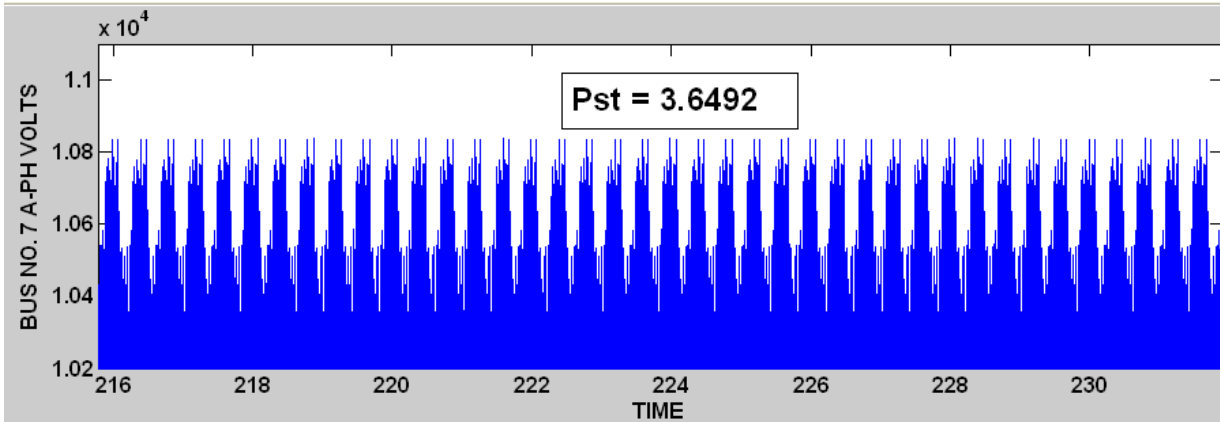

No Voltage Control
 $P_{st} = 3.6492$
(>0.9 - unacceptable)

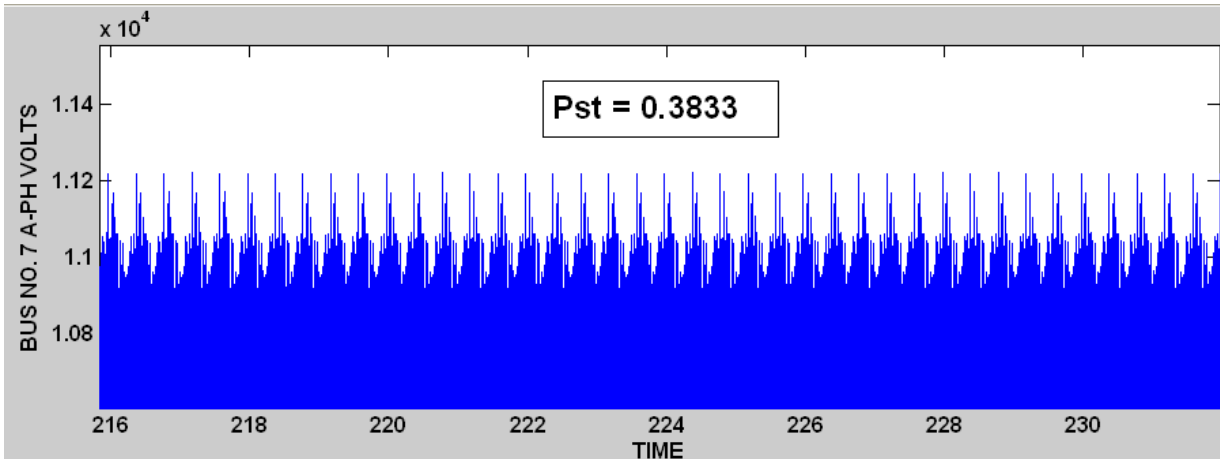

Fast Voltage Control
 $P_{st} = 0.3833$
(< 0.9 - acceptable)

Utility Solutions



MW in a Box – Oct 2010 SolarPro



- Larger Power Plants (20MW → 150MW and →500MW distributed)
- single plants, T & D
- distributed, D
- Perceived barriers at penetrations >15%
- voltage regulation, protection coordination, cloud and load variability
- Circuit ratings
- Trip, transfer trip, islanding

- Utility Assets, efficient, available, long life



Example

- **Fault studies limit DG penetration due to Recloser overload in substation with shared MV bus.**
- **Very big deal in some places today**
- **BUT, fault current is reactive as is traditional DG fault current.**
- **Inverter fault current?**
- **Much like inertia, what do you want it to be?**
- **Naturally the current is real, so orthogonal to fault current, but it could be capacitive if needed**

Micro Grids

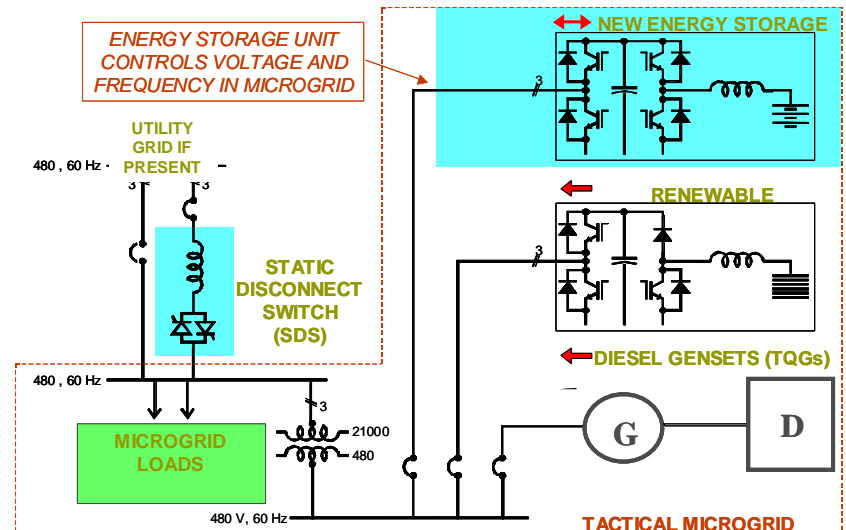
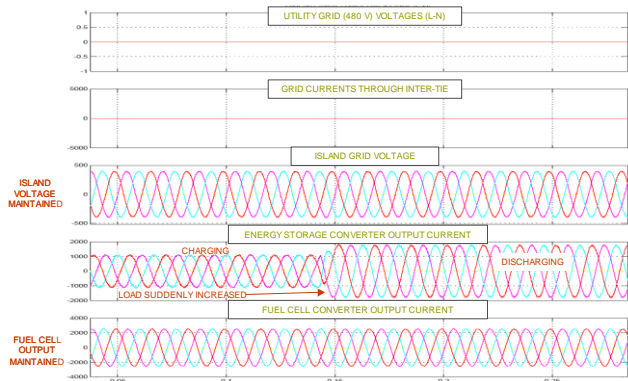
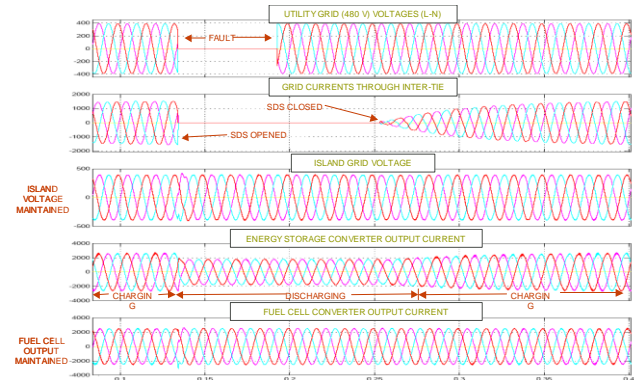
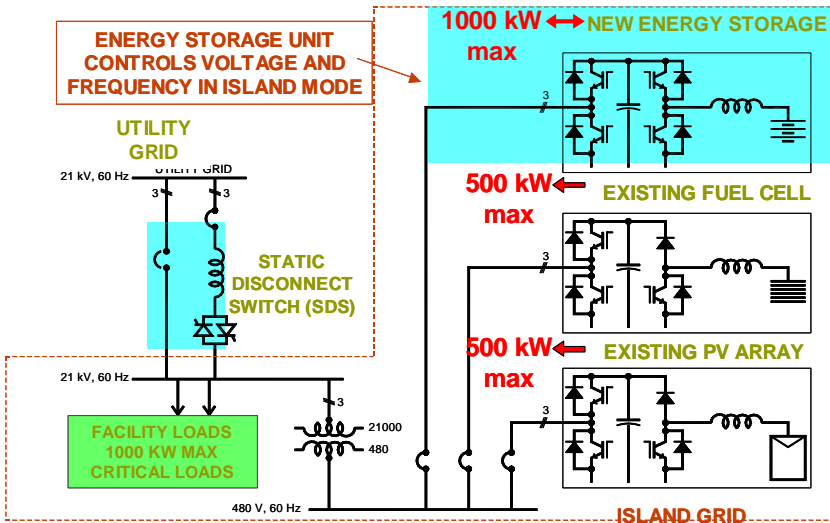

- Renewables plus back-up generation plus storage plus SDS
- UPS quality power

Need for Speed

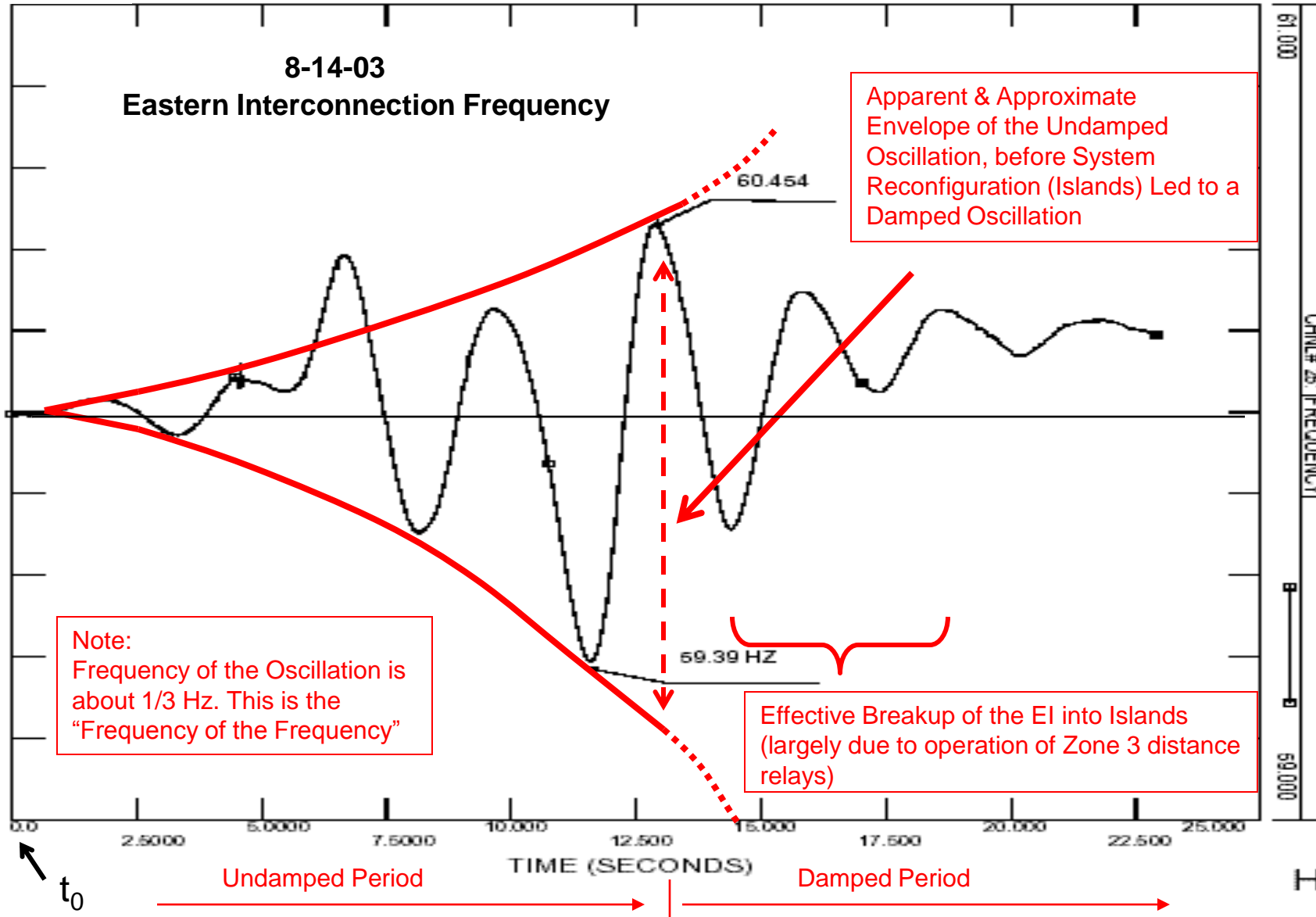

Summary

- **Costs, Controllability and Intermittency are the issues**
- **Inverters can solve some challenging problems, including the local effects of intermittency**
- **In many cases (faults a good example) Inverters and other high speed devices are the solution not the problem**
- **These high speed grid devices can truly enable a Faster, Smarter, Controllable, Greener, Distributed Grid**
- **High speed devices? STS, SDS, FCL, Breakers, ...**
- **Inverters as StatComs**
- **Shock Absorbers (disturbance mitigation), distributed?**
- **More DC, infrastructure, transmission, ...**
- **Control, local-autonomous-high speed, slower regional/area, PMU for control (not forensics only)**