

FUEL FACT SHEETS

Use these fact sheets to help students get started on their research.

CONTENTS

Battery Electric.....	68
Biodiesel.....	71
Ethanol.....	73
Fuel Cell Electric.....	75
Hybrid Electric.....	78
Liquefied Petroleum Gas (LPG.)	80
Methanol.....	82
Natural Gas.....	84
Solar Electric.....	86

BATTERY ELECTRIC

Electric vehicles (EVs) use electric motors instead of an internal combustion engine to provide motive force. In a battery electric vehicle, the power is stored on board vehicles in rechargeable battery packs, which power electronic drive systems. The electricity required to recharge the batteries may be provided by utility-generated power or by any other available source of electricity. Utilities generate power from a variety of sources, including coal, natural gas, nuclear energy, hydropower, and renewables.

HISTORY

Professor Sibrandus Stratingh is credited with building the first model of an electric car in the Netherlands in 1835. The first practical electric road vehicles were made soon after by Robert Davidson in Scotland and by

Thomas Davenport in the United States. Both inventors used nonrechargeable electric cells. When the Frenchmen Gaston Plante and Camille Faure invented (in 1865) and improved (in 1881) the electric storage battery, common use of electric vehicles became a possibility. In 1899, when the Belgian Camille Jenatzy set a record of over 100 kph (62 mph) in a streamlined electric racing car, the potential of the electric car was brought to the world's attention. By 1900, there were more electric than gas-powered cars on the road.

CURRENT USES

Before the widespread use of gasoline-fueled internal combustion engines and into the 1920s, electricity, stored in lead-acid batteries, was a popular energy source for vehicles. Only in recent years has serious attention returned to electric vehicles for automobile transportation purposes. Battery technology for vehicles is now changing with the support of the U.S. Advanced Battery Consortium (USABC), a partnership of the Department of Energy, DaimlerChrysler, Ford, and General Motors. The USABC predicts use in the near future of four types of batteries:

advanced lead-acid, nickel metal hydride, lithium-ion, and lithium-polymer.

When gasoline became the more popular fuel for on-road vehicles, EVs continued to be used off-road and for specialized functions. Even now, electric vehicles can be seen in factories and warehouses, where internal combustion engine exhaust could endanger worker health or damage products, and on golf courses, where their quiet operation provides a more relaxing environment. They are used in airports to move luggage, people, and planes; in law enforcement to enable a quiet approach by electric bicycle while expanding the range of the rider; on work sites to ferry employees between buildings; and on college campuses. To reduce pollution and noise in urban areas, cities are bringing back electric transit buses and trolleys.

SOURCES AND EFFICIENCY

Over 95 percent of the electricity used in the United States comes from domestic sources of energy. The nation's existing power plants are capable of producing the electricity needed to operate millions of EVs if these

vehicles are charged during off-peak hours. Widespread daytime charging of EVs will have an impact on the amount of electricity that will need to be produced.

According to the California Energy Commission, EVs are 0 to 25 percent more efficient than gasoline vehicles, and 10 to 30

percent less efficient than diesel vehicles. This comparison accounts for the entire fuel cycle — the energy used to extract, produce, and transport gasoline to the pump or to get the electricity to the plug, plus the energy used by the vehicle. Just taking the vehicle efficiency into account, an EV uses 66 percent of the electricity delivered to the charger for forward movement. An internal-combustion-engine vehicle uses approximately 22 to 33 percent of the gasoline's energy at the pump to move forward.

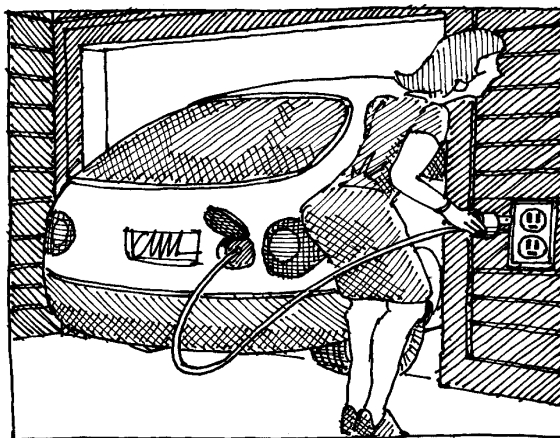
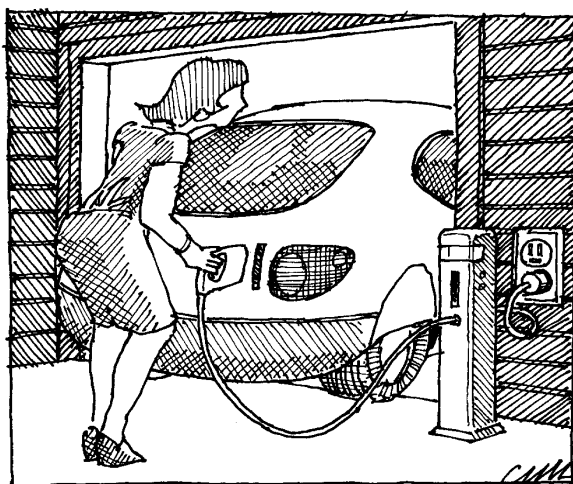

VEHICLE ALTERATIONS

The primary differences between a battery EV and a conventional vehicle are detailed below. A battery EV has an electric motor instead of an engine, a battery pack and management system instead of a fuel tank, electronic controls instead of an ignition system, and the addition of a high-voltage electrical system. An EV is propelled when the electric motor receives sufficient electricity from the battery pack to provide the torque needed to turn the wheels at the rate desired. The accelerator pedal is connected to an electronic control module, which regulates the amount of current or voltage drawn from the battery system. Most EVs use regenerative braking — slowing the vehicle by capturing kinetic energy, converting it back into electrical energy, and then channeling it to the battery pack for later use.

MAINTENANCE

Because an EV has few moving parts, service requirements are less than for conventional cars. An EV does not have an internal combustion engine, liquid fuel tank, fuel lines, carburetor, spark system, muffler, or pollution-control equipment. No timing belts, water pumps, radiators, fuel injectors, or tailpipes are required. No tune-ups, emission control adjustments, oil changes, or oil filter replacements are needed.

Lead-acid battery packs cost thousands of dollars and need replacement on average about every 30,000 miles or three years. Nickel-metal-hydride batteries may last up to 100,000 miles.

SAFETY

To promote safe use, vehicle manufacturers are using a number of disconnect systems in the high-voltage circuits, which isolate the rest of the vehicle from the battery voltage. Lethal levels of electricity may be present in the battery pack, however, so it should be treated with the same caution and respect as a full fuel tank in an internal combustion vehicle. In case of accidents, emergency response personnel will need special training to handle such hazards as exposure to high-voltage systems and possible leakage of flammable, toxic, or corrosive battery chemicals.

PERFORMANCE

A major difference between battery electric and internal-combustion-powered vehicles is the level of noise produced. Battery EVs are silent when idling and offer almost silent driving.

Acceleration, speed, and handling for well-designed EVs are equivalent to, or better than, those of comparable internal-combustion-powered vehicles. As of 1996, the world land-speed record for an electric car was just under 200 mph, and electric trains in Japan go even faster. In 1997, the top driving speed was 75 to 80 miles per hour, which may be limited by manufacturers in order to conserve battery power and extend the driving range. New battery EVs can accelerate from 0 to 60 mph in just 8.5 seconds and easily maintain highway speeds.

HOW A BATTERY ELECTRIC CAR WORKS

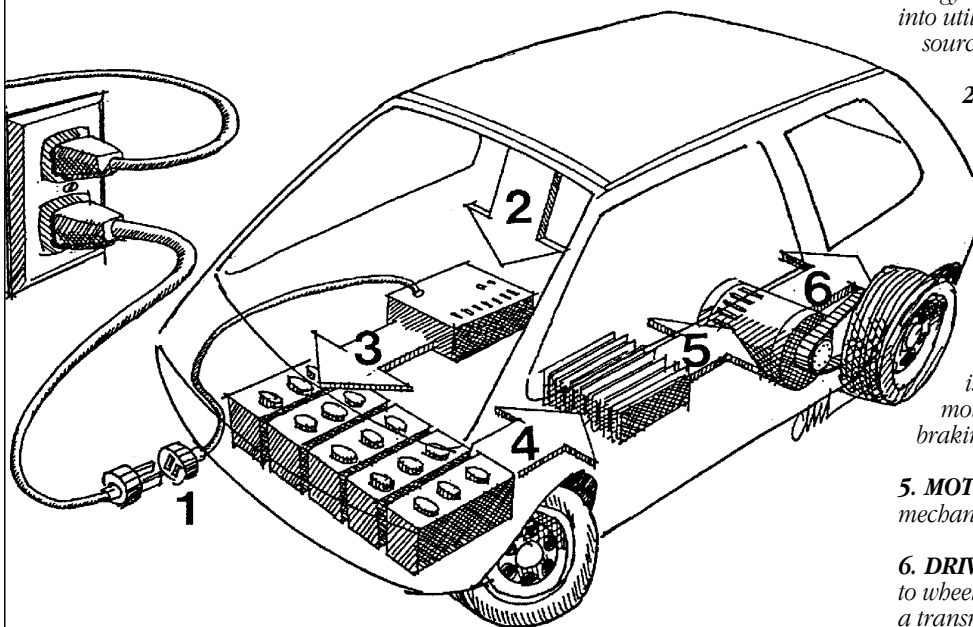

1. ELECTRICAL CONNECTION - enables the energy-storage system to be charged by plugging into utility-generated power or other available sources of electricity.

2. CHARGER - may be on or off the vehicle.

3. ENERGY-STORAGE SYSTEM - stores electricity until it is needed. The system may include batteries, supercapacitors, and/or a flywheel.

4. MOTOR CONTROLLER - sends electricity smoothly and efficiently to the motor as needed. It is controlled by an accelerator pedal. If regenerative braking is installed, the controller will allow the motor to act as a generator and return braking energy to the energy-storage system.

5. MOTOR - converts electrical energy to mechanical energy and vice versa.

6. DRIVETRAIN - transfers mechanical energy to wheels through a differential and sometimes a transmission.

RANGE AND RECHARGING

The average daily use of private vehicles in the major U.S. cities is 40 miles. Battery EVs average 40 to 125 miles per charge, depending on the vehicle's weight, engineering and design features, and type of battery. Weather extremes, terrain, and use of accessories such as heating and air conditioning also affect the range.

When the battery powers the motor, it discharges; that is, an electrical current flows, reducing the amount of electric charge stored in chemical form in the battery. Recharging a battery reverses this process. An electric current is passed through the battery and reforms the active materials in the battery to their high-energy charge state. Most homes, government facilities, fleet garages, and businesses have enough electrical power to charge EVs, but additional sources of power on the street, at shopping malls, or in parking structures would make recharging more convenient for battery EV drivers.

The time needed for charging depends on the voltage of the electrical source, and the temperature, size, type, and remaining state-of-charge of the batteries. Most EV batteries can be recharged using a grounded 120-volt, 15-amp, three-prong outlet found in most homes and buildings. This mode of charging is categorized as level 1 charging and takes 10 to 15 hours. Level 2 charging uses a 240-volt, 40-amp circuit, and takes 3 to 8 hours. The use of 480-volt equipment (level 3 charging) would enable recharging in as little as 5 to 10 minutes. This type of charging may be used in the future for public recharging sites.

Safely recharging an EV may require special hookups or upgrades to existing electrical outlets. To make the most efficient use of existing capacity, utilities will likely encourage home-based, overnight charging during off-peak hours.

EMISSIONS

Battery-powered electric vehicles produce no emissions in operation. This makes EVs a good choice for highly polluted urban areas, where human exposure to pollutants is greatest. EVs use virtually no energy while idling. In contrast, stop-and-go driving and idling increase the amount of pollutants per mile emitted from internal combustion engines. EVs can also help reduce the urban pollution that stems from running car air conditioners, carrying heavy loads, or driving in cold temperatures — all of which increase pollution from internal combustion engines.

Emissions do occur at the power-generating facilities that supply the electricity needed to recharge the battery, and the amount of emissions depends on the efficiency of recharging the batteries and the type of fuel used to produce power. An advantage of shifting emissions from tailpipes to power plants is that the emissions can be more easily controlled at a central location.

Electric drivetrains are more energy-efficient than are internal combustion engines. According to the California Energy Commission, EVs produce 90 percent fewer emissions than an internal combustion engine, even when emissions from power plants are considered.

The Argonne National Laboratory and the Union of Concerned Scientists (1995) have analyzed how the emissions of greenhouse gases would change if electric cars replaced gasoline-powered cars. The actual reduction of greenhouse gases depends on how the electricity used for charging is generated. The projected percentage of emissions reductions is shown below for each method of power production:

Coal-fired power plants: reductions of 17 to 22 percent.

Natural gas plants: reductions of 48 to 52 percent.

South Coast Air Basin of California, which relies on many sources of renewable energy: reduction of 71.2 percent.

Utilities using renewable energy sources (such as hydroelectric, wind, solar, or geothermal): reductions of almost 100 percent.

Nationwide: reductions of 31 to 46 percent.

OTHER ENVIRONMENTAL CONCERNS

No oil- or gasoline-caused water pollution is associated with EVs. Proper and safe disposal of batteries is important. Proper handling methods for lead-acid batteries are already in use, however, and more than 90 percent of lead-acid batteries are recycled in the United States. The acid is drained from the battery, cleaned, and recycled as electrolyte in new batteries; the lead is taken out and reused; even the plastic can be recycled. As other types of batteries are brought into use, similar environmentally responsible mechanisms for proper disposal and recycling will need to be developed and used.

BIODIESEL

Biodiesel (mono alkyl esters) is a renewable liquid fuel produced from new or used vegetable oils or animal fats. It is typically made by a chemical process called transesterification, which relies on an alcohol, such as methanol, and a catalyst. The main form of biodiesel in the United States is soydiesel, or methyl soyate, which is made from soybean oil. It can also be made from cottonseed, peanut, canola (a variety of rapeseed), sunflower oils, waste animal fats, and used cooking oil. The City of Chicago has made waste oil from restaurants into biodiesel fuel for use by the city's transit buses and marine police boats.

HISTORY

The concept of using vegetable oil as a fuel dates back to 1895, when Dr. Rudolf Diesel developed the first diesel engine to run on vegetable oil. Diesel demonstrated his engine at the World Exhibition in Paris in 1900, using peanut oil as fuel. Before World War II, biodiesel was introduced in South Africa to power heavy-duty vehicles.

Recently environmental and economic concerns have renewed the interest in biodiesel throughout the world, especially in Europe, where it has been used for 20 years. It is used by diesel-powered vehicles such as transit buses, heavy-duty trucks, and marine engines.

CURRENT USES

Biodiesel can be used alone or mixed in any ratio with petroleum diesel fuel. Biodiesel in its pure form is called "neat biodiesel." It is used in stationary generators in hospitals and police stations.

A number of fleets across the United States have adopted biodiesel blends. B20, a blend of 80 percent diesel and 20 percent biodiesel, is widely used in transit systems and in federal and municipal fleets such as postal vehicles, snowplows, road graders, and other highway maintenance vehicles. It is powering school bus systems in some U.S. cities and mass transit systems in national parks such as the Grand Canyon. Biodiesel blends are available in most marinas, where replacing diesel normally used in boats can help keep lakes, bays, and estuaries cleaner.

SOURCE, PRICING, AND AVAILABILITY

France is the world's largest producer of biodiesel, using it as heating oil and also in 50-percent blends with

petrodiesel. Currently all the biodiesel used in the United States comes from domestic feedstocks. The price varies greatly depending on the type and cost of the feedstock and the scale of production. (Prices are high when biodiesel is produced in small quantities.)

A variety of people are interested in developing biodiesel and in finding better, less-expensive feedstocks. Some food producers are interested because health-conscious Americans are eating less high-oil food, and biodiesel could provide another market for their products.

Scientists with the U.S. Departments of Energy and Agriculture are trying to develop soybean hybrids with a higher oil content. (Soybeans contain about 20 percent oil, whereas some oil seeds contain 50 percent; rapeseed used in Europe contains 40 percent.) The National Renewable Energy Laboratory (NREL) is researching the production of oil from aquatic plants, such as microalgae, a source that may greatly lower the cost of biodiesel.

STORAGE AND SAFETY

Biodiesel can be stored anywhere that petroleum diesel fuel is stored; neat biodiesel begins to freeze at about 25° F, however, so it needs to be used or stored at temperatures above that. (Underground storage tanks are usually

about 50° F.) Biodiesel has a high flash point and does not produce explosive vapors, making it safer to store and handle than diesel, but biodiesel has a shelf life of about six months, after which its fuel properties should be reanalyzed.

Biodiesel fuel can be distributed through the existing diesel supply infrastructure. Because it softens and dissolves some substances, fuel hoses may need modification. Biodiesel can also dissolve certain types of paints.

Neat biodiesel is biodegradable, degrading four times faster than diesel and at the same rate as dextrose (a sugar). Compared with diesel, it has substantially lower toxic, mutagenic, and carcinogenic emissions; it is relatively nontoxic to mammals.

In the late '90s, Yellowstone National Park conducted a "bear attraction test," successfully dispelling the notion that the french fry smell of biodiesel would attract bears to cars.

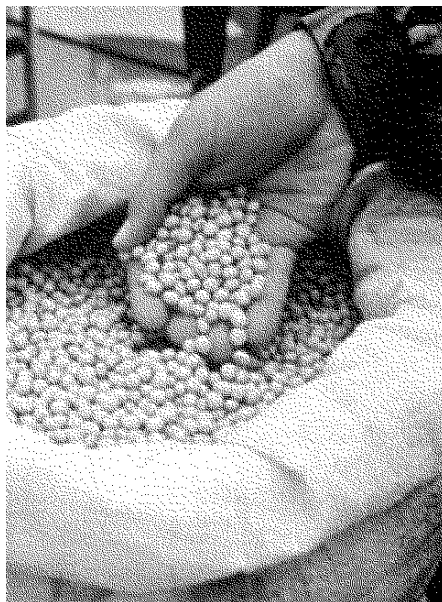

PERFORMANCE

The energy content, viscosity and phase changes, horsepower, torque, and fuel economy are similar to those for conventional and low-sulfur diesel. Biodiesel has a significantly higher cetane number, a number that rates its starting ability and antiknock properties.

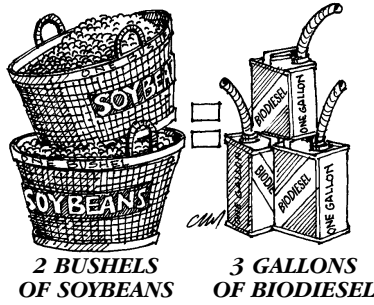

EMISSIONS

A 1998 biodiesel life-cycle study, jointly sponsored by the U.S. Department of Energy and the U.S. Department of Agriculture, concluded that producing and using biodiesel reduces net CO₂ emissions by 78 percent compared with petroleum diesel. This is due to biodiesel's closed carbon cycle.

Growing plants that are later processed into fuel recycles the CO₂ released into the atmosphere when biodiesel is burned.

At higher temperature extremes, biodiesel is advantageous because its flash point is over 300°F, compared with 125°F for low-sulfur diesel and 176°F for conventional diesel. Compared with regular diesel, biodiesel is more susceptible to cold-weather fuel-flow problems. These problems can be overcome by installing engine or fuel-filter heaters, storing vehicles near or in a building, or blending biodiesel with conventional diesel.

In the late '90s, Yellowstone National Park tested biodiesel by successfully driving a park truck more than 92,000 miles. Compared with diesel trucks, toxicity, emissions, smoke, and unpleasant odors were reduced; safety and biodegradability were increased.

REFUELING

Fueling is the same as with diesel fuel.

Other tests comparing biodiesel with diesel show these results:

MAINTENANCE AND VEHICLE ALTERATIONS

An engine using biodiesel requires little modification. But since biodiesel is a natural solvent that can dissolve some rubber, vehicle fuel lines and fuel pump seals that come in contact with the fuel could be affected by pure or high-percent blends. For many new cars, the recent switch to low-sulfur diesel fuel has caused most original engine manufacturers to switch to components that are already suitable for use with biodiesel. Because the fuel clouds and stops flowing at higher temperatures than does diesel, fuel-heating systems may be needed in cold climates.

Carbon monoxide: 50 percent reduction

Total unburned hydrocarbons: 93 percent reduction

Ozone-forming potential due to reactive hydrocarbons: 50 percent reduction

Toxic hydrocarbons: most were reduced by 75 to 85 percent.

Nitrogen oxides: Either slightly reduced or slightly increased, depending on the engine family and testing procedures. The National Biodiesel Board reports that a 13 percent increase can be remedied through changes in ignition timing and the use of proper catalytic converter technology.

Particulate matter: 30 percent reduction

Sulfur: 100 percent reduction.

The use of biodiesel, even in small percentages, can extend the life of diesel engines because it is more lubricating than petroleum diesel fuel.



ETHANOL

Ethanol is a clear, colorless liquid alcohol, which is also called ethyl alcohol, grain alcohol, or ETOH. Ethanol is a renewable source of energy made by fermenting any biomass high in carbohydrates (starch, sugar, and cellulose) through a process similar to brewing beer. It is most commonly produced from field corn, sugar cane, or wheat, but is also being made from other grains, cheese whey, and waste from the beverage, brewery, and wine industries. New technologies may soon enable the production of ethanol from cellulose from rice straw, forest residue, sawdust, pulp and paper sludge, and dedicated energy crops such as switchgrass, prairie grass, and fast-growing poplar trees.

HISTORY

Ethanol has been used as a transportation fuel since Henry Ford and other transportation pioneers began developing automobiles. In the 1880s, Ford used ethanol to fuel one of his first automobiles, the quadricycle. In 1908, the Ford Model T was designed with a carburetor adjustment that could allow the vehicle to run on ethanol fuel produced by American farmers. Ford's vision was to "build a vehicle affordable to the working family and powered by a fuel that would boost the rural farm economy."

During the 1930s, more than 2,000 service stations in the Midwest sold ethanol made from corn, but the ethanol industry closed down in the '40s with the coming of low-priced petroleum. During World War I and II in both the United States and in Europe, alcohol fuels supplemented supplies of oil-based fuels. During World War II, the government even commandeered whiskey distilleries for alcohol fuel production. In recent history, public interest in alcohol as a transportation fuel has changed with periods of war and the fluctuating supply and price of oil. The oil crisis in the 1970s raised the price of oil and gas and gave birth to the gasohol era, when gasoline was extended with the addition of 10 percent ethanol. (Gasohol is not considered an alternative fuel.) When gasoline became more plentiful, ethanol was blended with gasoline to increase the octane rating, and the name gasohol was replaced with names reflecting the increased octane. Unleaded plus or super unleaded are two examples of names used today.

CURRENT USES

Ethanol-powered vehicles have been used in countries that produce crops suitable for ethanol

production; for example, in Brazil more than four million ethanol vehicles run on ethanol produced from sugar cane. In the United States, vehicles using mixtures of ethanol and gasoline can be found in the Midwest, where much of the corn used to make ethanol is grown and processed into fuel. Ethanol fueling sites were first established in Illinois, Iowa, South Dakota, Minnesota, and Colorado.

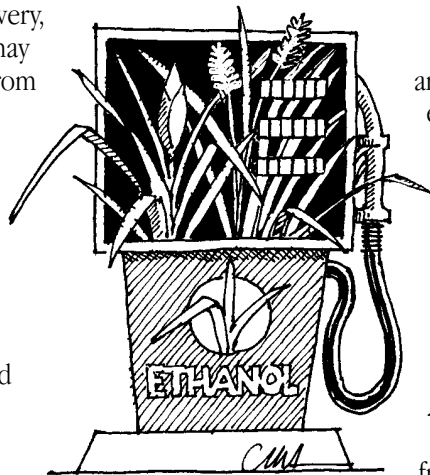

Ethanol is most commonly used in cars and light trucks in a blend of 85 percent ethanol and 15 percent gasoline called E85. E95, a blend of 95 percent ethanol and 5 percent gasoline, is used in heavy vehicles. Ethanol is also a component of reformulated gasoline and is used in some regions of the country to reduce carbon monoxide emissions.

SOURCE, PRICING, AND AVAILABILITY

In the United States, most ethanol is made from corn. In the 1990s, all of the ethanol used for vehicle fuel originated within U.S. borders. The price of ethanol is influenced by seasonal changes in the availability and price of feedstocks used to make it. For example, flooding of the Mississippi River in 1993 resulted in a smaller corn crop, which briefly raised the price of corn and the regional price of ethanol fuel. Prices are also affected by competing demands for ethanol, such as its use in reformulated gasoline or gasohol.

STORAGE AND SAFETY

Because ethanol is toxic if ingested, it is denatured to prevent consumption. It may also contain additives that could be harmful if inhaled or consumed. Although ethanol is harmful to organisms, it rapidly biodegrades in surface water, groundwater, and soil, thus rendering it harmless. Because ethanol can be corrosive to some metals and damaging to rubbers (gaskets and seals), fuel-storage tanks and dispensing equipment must be corrosion and damage resistant. Ethanol has a low vapor pressure and a broad range of flammability. Ethanol burns in air with a visible blue flame.

PERFORMANCE

Power, acceleration, payload, and cruise speed are comparable with those of other fuels. Ethanol is a high-octane fuel. When added to gasoline, it boosts the octane levels to help the car run more smoothly.

RANGE AND REFUELING

If the compression ratio is optimized for a higher octane rating, ethanol has approximately 80 percent or more of the energy density of gasoline. The lower energy content yields a slightly lower driving range per gallon (75 to 90 percent); therefore, an ethanol-powered vehicle requires more frequent fueling. As with gasoline or diesel fuel, ethanol is dispensed from pumps.

MAINTENANCE AND VEHICLE ALTERATIONS

Maintenance of ethanol-powered vehicles is similar if not identical to that of gasoline-powered vehicles; some of the parts and lubricants must be specially designed, however. For example, because ethanol is corrosive, noncorroding hoses must be used, and stainless-steel fuel tanks are required. The compression and timing features must be modified. Ethanol doesn't leave waxy deposits, as does gasoline, so the fuel system remains cleaner.

Diesel engines cannot simply be converted to ethanol operation. Ethanol has a very low cetane number, which describes the ability of a fuel to be ignited in compression-ignition diesel engines. One conversion approach is using the direct injection of ethanol, which will, after other slight adjustments to the engine, allow proper ignition of ethanol.

EMISSIONS

In December 1997, the U.S. Department of Energy conducted a fuel-cycle study that included the energy required to grow and harvest the corn, distill it into ethanol, and transport the ethanol to gasoline terminals. Plants grown for ethanol production absorb carbon dioxide during growth, which partially offsets the carbon dioxide emitted during fuel combustion. Studies concluded that compared with conventional gasoline, ethanol produced from corn reduces fossil energy use by 50 to 60 percent and greenhouse-gas emissions by 35 to 46 percent. Ethanol produced from cellulose materials can reduce greenhouse gas emissions even more.

Ethanol contains no sulfur, an element that reduces the effectiveness of emissions control devices. Without sulfur, emissions control devices work better, thereby reducing emissions of other pollutants.

Ethanol contains 35 percent oxygen by weight. When added to gasoline, ethanol (and other oxygenates) enhances combustion, resulting in a more efficient burn. This greatly reduces exhaust emissions, including hydrocarbons, NO_x and CO (precursors to ozone), fine particulates, and toxics.

ETHANOL IN THE CARBON CYCLE

Crops such as sugar cane, wheat, and corn are trucked to a processing plant where they are finely ground, separated into their component sugars, and distilled to make ethanol.

Ethanol is trucked to fueling stations, where it is sold as an alternative fuel for use in cars. Cars release carbon dioxide and other emissions.

Sugar cane, wheat, and corn

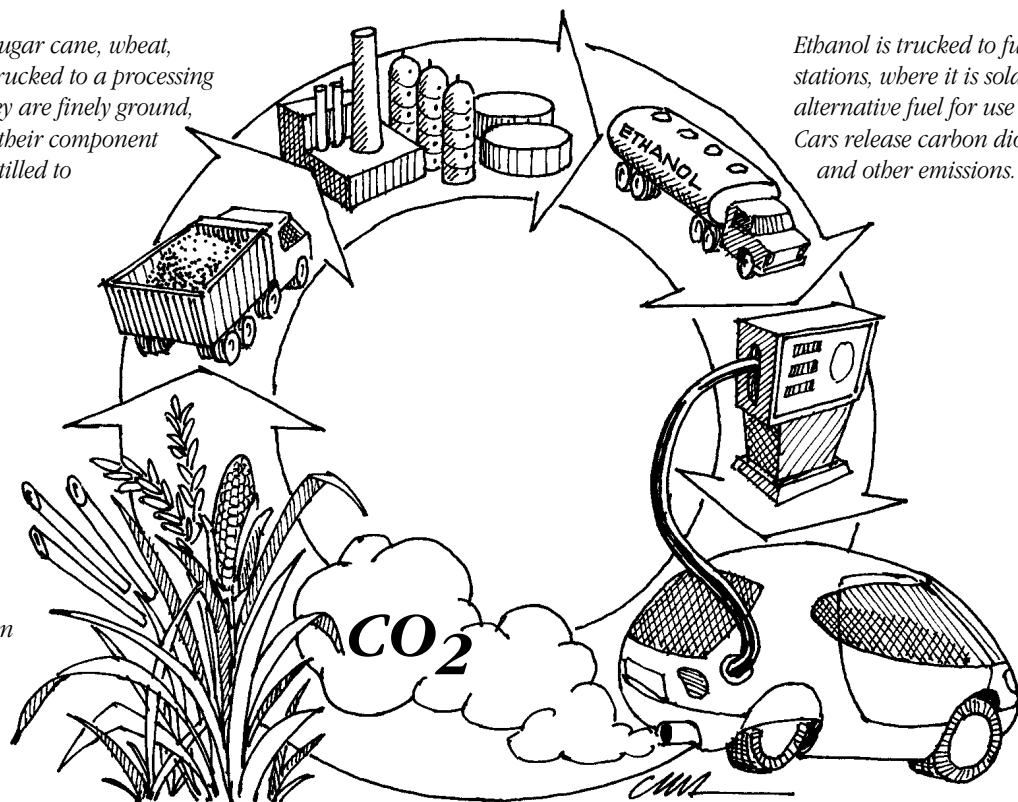

Growing more of the original crops absorbs the carbon dioxide. The other emissions are less than those of a gasoline-powered car.

FUEL CELL ELECTRIC

Electric vehicles use electric motors instead of an internal combustion engine to provide motive force. In development are vehicles that use an electrochemical system, known as a fuel cell, to produce onboard power. Unlike batteries, where electrical energy is converted into stored chemical energy through electrical charging, fuel cells use chemical energy coming from a fuel, which is stored on board, to produce electric energy. Fuel cells continuously convert the chemical energy of hydrogen from the fuel and oxygen from the air to produce electric energy, heat, and water. This electricity is used by motors connected to axles to power the wheels of the vehicle.

HISTORY

William Grove, a British jurist and amateur physicist, first discovered the principle of the fuel cell in 1839. A hundred and twenty years later, NASA developed fuel cells for use during space flight, where they have provided electricity and drinking water for astronauts. Since the space program demonstrated the potential for fuel cell technology, industry has been interested in developing it further. Since 1984, the U.S. Department of Energy has been supporting fuel cell research and development.

Fuel cells are expected to be used widely because they can produce power much more efficiently and cleanly than can fossil or nuclear fuel. Some large office buildings

use stationary fuel cells for their own electricity and for hot water and supplemental space heating. Fuel cell technology is being developed to meet similar electrical and heating energy needs on the smaller scale appropriate for individual homes. In March 1998, Chicago became the first city in the world to power buses with hydrogen fuel cells.

CURRENT RESEARCH IN TRANSPORTATION

There are five distinct types of fuel cells, two of which are being seriously considered for land-based vehicles: the phosphoric acid fuel cell (PAFC) and the polymer electrolyte membrane, or proton exchange membrane (PEM).

- PAFC, already used by stationary power generators, may be used in larger vehicles such as transit buses.
- Vehicle manufacturers around the world are investigating the PEM fuel cell because it provides a continuous electrical energy supply at a high level of efficiency and power density.

SOURCES

All fuel cell vehicles (FCVs) currently require some form of hydrogen — either in a pure state or in combination with other elements. Hydrogen is the lightest and most abundant element on earth, making up about 93 percent

PEM FUEL CELL

At the center of the PEM fuel cell is an electrolyte membrane, which looks like a moist piece of thick plastic wrap (as thick as 2 to 7 pieces of paper). It keeps hydrogen fuel separate from oxidant air. Fuel cell operation depends on movement of hydrogen ions through the membrane (electrolyte) in one direction only (from anode to cathode).

As hydrogen flows into the fuel cell on the anode side, a platinum catalyst facilitates the separation of the hydrogen gas into electrons and protons (hydrogen ions).

The hydrogen ions pass through the membrane.

With the help of a platinum catalyst on the cathode side, they combine with oxygen and electrons, producing water.

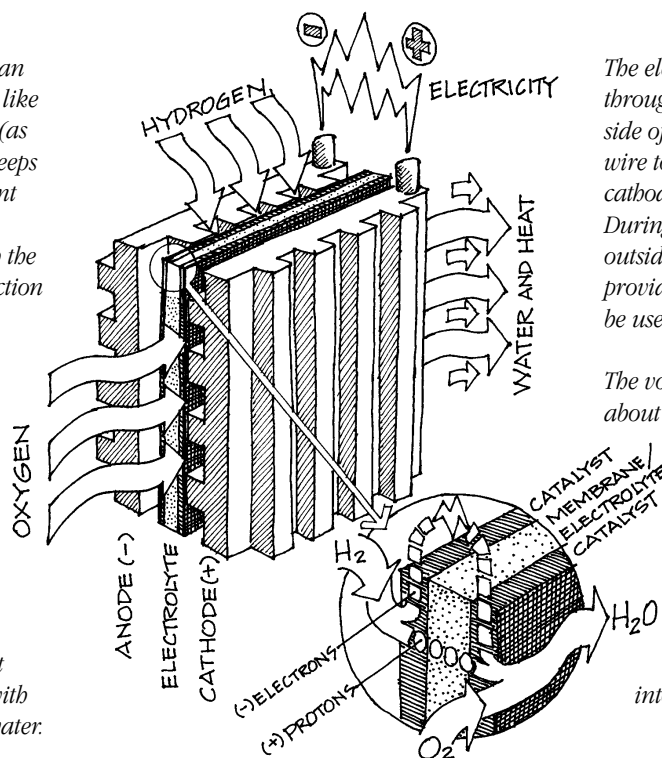

The electrons (which cannot pass through the membrane) flow from one side of the cell (the anode) through a wire to the other side of the cell (the cathode) in order to complete the circuit. During their route through the circuits outside the fuel cell, the electrons provide electrical power, which can be used to run a car.

The voltage from one single cell is just about enough for a light bulb. When cells are stacked in series, the operating voltage increases. A fuel cell stack can consist of a few cells to a hundred or more cells connected in series, depending on the amount of power needed. Fuel cell stacks are integrated into a fuel cell engine.

of all atoms and 76 percent of the mass of the universe. It is found in water, all plants and animals, and fossil fuels.

Although hydrogen is abundant in many compounds, obtaining enough pure hydrogen for popular use and developing the infrastructure for fueling private cars with pure hydrogen pose a challenge. Dispensing hydrogen fuel for fleets of large trucks or buses is easier to envision. In that case, liquid hydrogen would be trucked from central production facilities to fuel dispensing facilities, where cryogenic pumps would be used to load gaseous hydrogen fuel onto vehicles.

Fuel cells can also operate on hydrogen that is stripped on board the vehicle from hydrocarbons found in gasoline, methanol, or other fuels.

- Methanol, a simple fuel made of four hydrogen molecules, one carbon molecule, and one oxygen molecule, is an excellent source of hydrogen and can be easily distributed through the existing fuel infrastructure with minor modifications.
- Natural gas (methane) is also an excellent hydrogen carrier, although a widespread natural gas distribution system for cars does not yet exist.
- Gasoline, formulated without sulfur, could also be used. It could be distributed through the same distribution system as other gasoline products. Although reliance on gasoline would prolong U.S. dependence on foreign oil, fuel cells would reduce the amount of gasoline used because they are two to three times more efficient than internal combustion engines in converting fuel to power.

- Sodium borohydride, a derivative of borax, has also shown promise in powering fuel cells. Borax is found throughout the world in substantial natural reserves. In a chemical process that releases pure hydrogen for fuel cells, the only by-products are water and naturally occurring minerals called borates, which can be reclaimed as a source of fuel. It could be distributed, with minor modifications, through the existing fuel infrastructure.

VEHICLE ALTERATIONS

Vehicle alterations depend on the type of fuel that is used by the fuel cell to produce power. A direct hydrogen fuel cell would involve no combustion and would not need any pollution- or noise-control devices. Hydrogen may be stored on board in compressed high-pressure gas cylinders, as a liquid in insulated storage tanks at low temperature and pressure, as a metal hydride, or as some other hydrogen-rich solid or liquid fuel, such as sodium borohydride. A fuel cell-based propulsion system relying on gasoline, methanol, or methane for hydrogen includes a fuel cell stack, a reformer and catalytic burner, a cooling device, and an air compressor/expander. (The onboard reformer is a device that uses heat and catalysts to break the strong hydrocarbon bonds in the gasoline, methanol, or methane used as a source of hydrogen.) A high-pressure cylinder is needed if methane is used. A fuel tank or gas cylinder is needed to carry hydrogen or hydrogen-rich liquid fuel. Cars using sodium borohydride as a source of hydrogen would need a waste tank to hold the spent fuel until it could be recycled into new fuel.

HOW A HYDROGEN FUEL CELL ELECTRIC CAR WORKS

1. FUEL TANK - holds hydrogen as a compressed gas at high pressure, as a liquid in insulated storage tanks at low temperature and pressure, as a metal hydride, or as some other solid fuel.

2. FUEL CELL SYSTEM - combines hydrogen and oxygen to generate electricity.

3. COMPUTER - decides whether to store electricity in the battery or send it directly to the motor.

4. BATTERIES - store electricity until it is needed.

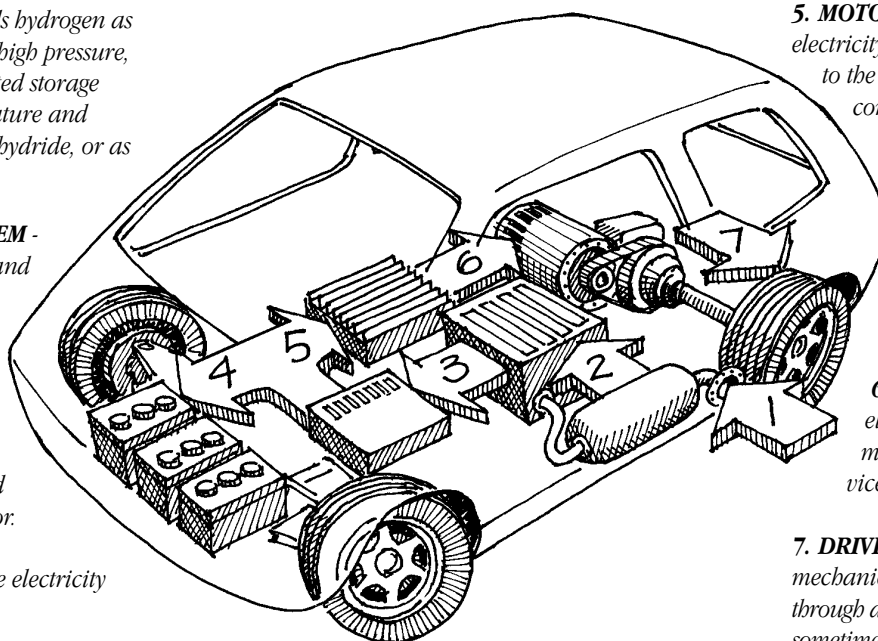

5. MOTOR CONTROLLER - sends electricity smoothly and efficiently to the motor as needed. It is controlled by an accelerator pedal. If regenerative braking is installed, the controller will allow the motor to act as a generator and return braking energy to the energy-storage system.

6. MOTOR - converts electrical energy to mechanical energy and vice versa.

7. DRIVETRAIN - transfers mechanical energy to wheels through a differential and sometimes a transmission.

As with other EVs, a typical fuel cell vehicle has an electric motor instead of an internal combustion engine, electronic controls instead of an ignition system, and the addition of a high-voltage electrical system. Fuel cell systems for automobiles also include a small battery pack as a buffer between the fuel cell stack and the electric motor.

An EV is propelled when the electric motor receives sufficient electricity from the battery pack to provide the torque needed to turn the wheels at the rate desired. The accelerator pedal is connected to an electronic control module that regulates the amount of current or voltage drawn from the battery system. Most EVs use regenerative braking — slowing the vehicle by capturing kinetic energy, converting it back into electrical energy, and then channeling it to the battery pack for later use.

MAINTENANCE

Because a PEM fuel cell stack has no moving parts, maintenance is minimal. An FCV's reformer and catalytic burner, cooling device, and air compressor/expander need regular maintenance, however.

STORAGE AND SAFETY

Care needs to be taken in transporting and refueling whatever gaseous, liquid, or solid fuel is used to power the fuel cell. Hydrogen storage and transportation systems will need to be engineered to be as safe as the fuel systems in current automobiles. Storage and transportation of methanol are similar to those of gasoline. Yet, because methanol is corrosive to some metals and damaging to rubber and some plastics, fuel storage tanks and dispensing equipment must be corrosion and damage resistant. California requires that underground storage tanks for methanol be double walled. Unlike other hydrogen carriers, sodium borohydride is not flammable. Storage and transportation are similar to those of gasoline.

With high-voltage circuits, vehicle manufacturers are using a number of disconnect systems to isolate the rest of the vehicle from the fuel cell's voltage. Lethal levels of electricity may be present, however, so the fuel cell's electrical system should be treated with the same caution and respect as a full fuel tank in an internal combustion engine.

PERFORMANCE

Acceleration, speed, and handling for well-designed EVs are equivalent to, or better than, those of comparable internal-combustion-powered vehicles. As with other electric-drive vehicles, fuel cell cars are quiet.

RANGE AND REFUELING

PEM fuel cells, which rely on liquid fuel, provide an acceptable driving range. Compared with conventional vehicles, FCVs will use fuel more efficiently, traveling as far

as 80 miles per gallon. This longer range is due in part to the efficiency of the fuel cell power system and in part to the lighter weight of an FCV. (It has a smaller fuel tank and lacks a large internal combustion engine. For larger scale applications, fuel cells are smaller and lighter than batteries.)

Refueling a private automobile will likely involve replacing the hydrogen-rich fuel, such as liquid gasoline, methanol, or sodium borohydride, at existing fueling stations. This refueling takes much less time than recharging a battery.

If using compressed natural gas (CNG), refueling can be "slow" (generally taking six to eight hours and commonly done overnight) or "quick" (about five minutes, which is comparable to a gasoline fill-up). Overnight refueling is possible in individual homes with small compressors, which may be located in a home's garage and connected to the natural gas supply of the house.

EMISSIONS

In order to make a clear comparison with other fuels and fuel systems, the entire life cycle of a fuel cell must be analyzed. That includes the process of manufacturing and of safely disposing of fuel cells that have limited use. The fuel cell itself is potentially a pollution-free energy technology, even when idling in stop-and-go traffic. In contrast, conventional vehicles produce most of their emissions under such conditions. There are no evaporative emissions from the fuel cell stack. Only water vapors are produced.

When run on pure hydrogen, fuel cells are true zero-emission vehicles. In these systems, hydrogen chemically combines with oxygen, producing only electricity, water, and waste heat. Since no carbon is involved, emissions of carbon monoxide, carbon dioxide, and ozone-forming compounds are eliminated. There are no nitrogen oxides.

Fuel cells that rely on gasoline, methanol, or other carbon-based fuels as a source of hydrogen produce small amounts of tailpipe emissions (e.g., sulfur dioxide and nitrogen oxides), with water and carbon dioxide being the major by-products. Compared with traditional combustion engines, methanol fuel cells cut smog-forming pollution more than 90 percent. Because of their efficiency, fuel cell vehicles can cut greenhouse-gas emissions by more than half.

As fuel cell vehicle technology develops, emissions levels are expected to be further reduced. As fuel reformers become smaller and more optimized for low emissions, FCVs operating on methanol are expected to have nearly zero emissions.

HYBRID ELECTRIC

A hybrid electric vehicle (HEV, or “hybrid”) uses both electrical and mechanical energy to propel it. It combines the efficiency of electrical drive systems with the longer driving range provided by liquid or gaseous fuels.

HISTORY

From the 1830s until the 1920s, electricity, stored in lead-acid batteries, was a popular energy source for vehicles. Electricity is a highly efficient means of propelling vehicles; the range of battery electric vehicles is relatively short, however, because the energy density of batteries is low compared with that of liquid or gaseous fuels. When petroleum became an inexpensive and widely available fuel, electric vehicles lost their popularity as long-distance vehicles.

Because of their quiet operation and lack of exhaust, they continued to be used off road in factories, warehouses, and golf courses.

Hybrid power systems were conceived as a way to extend the range of electric vehicles for on-road use. Early designs assumed that HEVs would get most of their power from wall-plug electricity. For longer trips, an onboard generator powered by an internal combustion engine would extend the power needed. This system was expected to be as efficient and emission free as possible until better batteries were developed that made hybrids unnecessary.

In recent years, design approaches for HEVs have changed. They no longer rely on wall-plug electricity and are no longer seen as transitional vehicles. Most experts feel that the car of the near future will be an HEV of some kind.

RESEARCH

From 1993 to 2002, two programs supported research and development of hybrid vehicles in the United States: the Department of Energy’s HEV Program and the Partnership for a New Generation of Vehicles (PNGV) Program. The latter was a collaboration between the federal government and the Big Three automakers — Ford, General Motors, and DaimlerChrysler. The goals of the two programs were closely aligned. The HEV Program aimed to develop HEV drivetrains and other internal components that would be twice as fuel efficient as those of conventional vehicles. The PNGV Program researched vehicle characteristics that affect fuel efficiency — such as the chassis, body, aerodynamics, and rolling resistance — with the goal of

developing HEVs that achieve up to 80 miles per gallon, or three times the fuel economy of conventional 1993 vehicles.

Auto manufacturers throughout the world are interested in HEVs. The Japanese were the first to market them: Toyota introduced the first HEV in Japan in 1997. In 1999, Honda sold the first gasoline-electric hybrid in the United States.

SOURCES

The first model hybrids depended on gasoline, but hybrids can be designed to operate on a wide variety of gaseous or liquid fuels, including fossil fuels or a renewable alternative fuel such as biodiesel or ethanol.

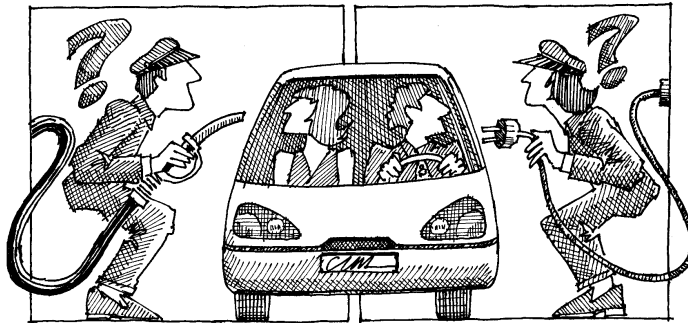

VEHICLE ALTERATIONS

Hybrids essentially combine a mechanical power unit, an electrical energy storage system, and a propulsion system. Many combinations or configurations are possible. The power unit may be a spark-ignition engine, compression ignition direct-injection engine, gas turbine, or fuel cell. The energy storage system may be a battery, ultracapacitor, or flywheel. Propulsion may come entirely from the electric motor or from both the motor and power unit.

Several vehicle alterations lead to greater fuel economy for hybrids than with traditional vehicles. If an internal combustion engine is used, the engine can be smaller and lighter because it shares the workload with the electrical motor. The engine can be optimized to operate within a speed range where fuel economy is greatest. HEVs typically use regenerative braking, which slows the vehicle by capturing kinetic energy, converting it to electricity, and channeling it to the battery pack, thus minimizing the energy lost when slowing down.

MAINTENANCE

Because HEVs have combined systems, they are more complex than either battery-powered or conventional vehicles. Maintenance schedules and the cost of parts and service are expected to be higher than for other types of vehicles.

SAFETY

Care needs to be taken in transporting and refueling whatever gaseous or liquid fuel is used to power the hybrid. For batteries, vehicle manufacturers are using a number of

HOW A HYBRID ELECTRIC CAR WORKS

1. FUEL TANK (or high-pressure cylinders) - contains gasoline, diesel, methanol, ethanol, compressed or liquid natural gas.

2. SPARK OR COMPRESSION IGNITION ENGINE - converts fuel to mechanical energy.

3. IN PARALLEL SYSTEMS - engine may provide power directly to the drivetrain (transmission and/or differential)

4. GENERATOR - driven by the engine, it converts mechanical energy to electrical energy in both parallel and series hybrids.

5. COMPUTER - decides whether electric power from the onboard generator or an external power source is stored in the battery or sent directly to the motor. (In parallel systems, a computer also controls when power to the drivetrain comes from the engine and from the motor.)

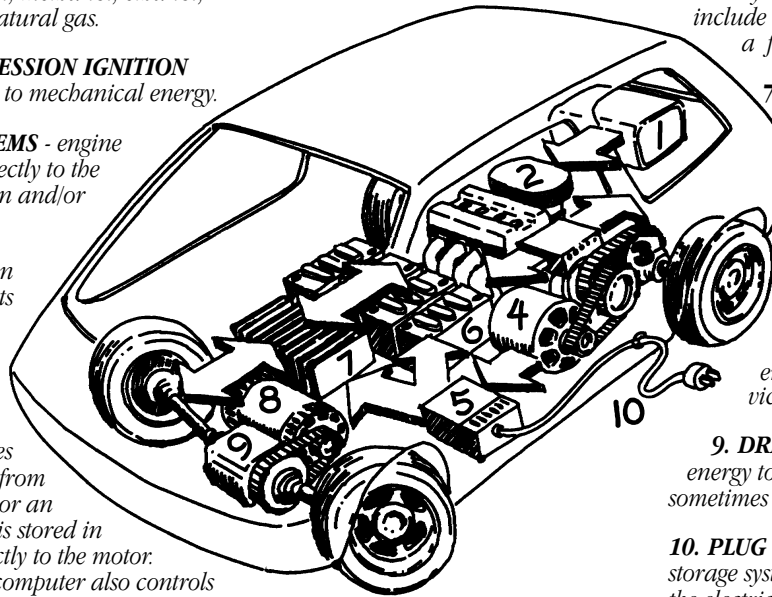

6. ENERGY-STORAGE SYSTEM - stores electricity until it is needed. The system may include batteries, supercapacitors, and/or a flywheel.

7. MOTOR CONTROLLER - sends electricity smoothly and efficiently to the motor as needed. It is controlled by an accelerator pedal. If regenerative braking is installed, the controller will allow the motor to act as a generator and return braking energy to the energy-storage system.

8. MOTOR - converts electrical energy to mechanical energy and vice versa.

9. DRIVETRAIN - transfers mechanical energy to wheels through a differential and sometimes a transmission.

10. PLUG - if installed, enables the energy-storage system to be charged by plugging into the electric grid, or by home-mounted solar collectors.

disconnect systems in the high-voltage circuits, which isolate the rest of the vehicle from the battery voltage. Lethal levels of electricity may be present in the battery pack, however, so it should be treated with the same caution and respect as a full fuel tank in an internal combustion vehicle. In case of accidents, emergency response personnel will need special training to handle such hazards as exposure to high-voltage systems and possible leakage of flammable, toxic, or corrosive battery chemicals and/or fuel.

PERFORMANCE

HEVs are meeting or exceeding the performance of conventional vehicles.

RANGE AND REFUELING

Gasoline-powered HEVs are rapidly refueled and need fueling less often. Toyota Motor Company reports that its Prius, the first gasoline-powered HEV, gets 48 combined highway/city miles per gallon. According to Honda, its

Insight — the first hybrid sold in the United States — gets 61/68 city/highway miles per gallon. U.S. automakers aim to create a vehicle getting 80 miles per gallon.

EMISSIONS

Because hybrids are two to three times as fuel efficient as conventional vehicles, emissions per mile are greatly decreased. The type of emissions depends on the by-products of the specific fuel used. The first hybrids, which use gasoline, cut emissions of greenhouse gases by a third to a half; later models may cut emissions even more.

Toyota Motor company reports that the Prius greatly reduces emissions: 50 percent for carbon dioxide and 90 percent for carbon monoxide, hydrocarbons, and nitrogen oxides. The Prius is rated by the California Air Resources Board as a super ultra low-emission vehicle (SULEV), and the Insight is rated as an ultra low-emission vehicle (ULEV).

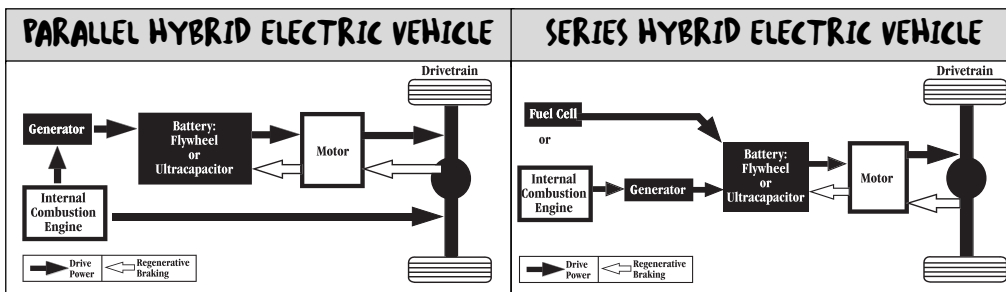

In a parallel configuration, the drive system can be powered simultaneously by the electric motor and the mechanical device. For example, during acceleration, passing, or hill climbing, the electric motor and internal combustion engine can both provide power to the drivetrain. Once the vehicle reaches cruising speed, the hybrid relies solely on the engine to maintain speed.

In a series configuration, the drivetrain is powered solely from the motor, which is connected to the electrical storage device. The power unit (internal combustion engine, turbine, or fuel cell) generates electricity to charge the electrical storage device (e.g., battery, flywheel, or ultracapacitor).

LIQUEFIED PETROLEUM GAS (LPG)

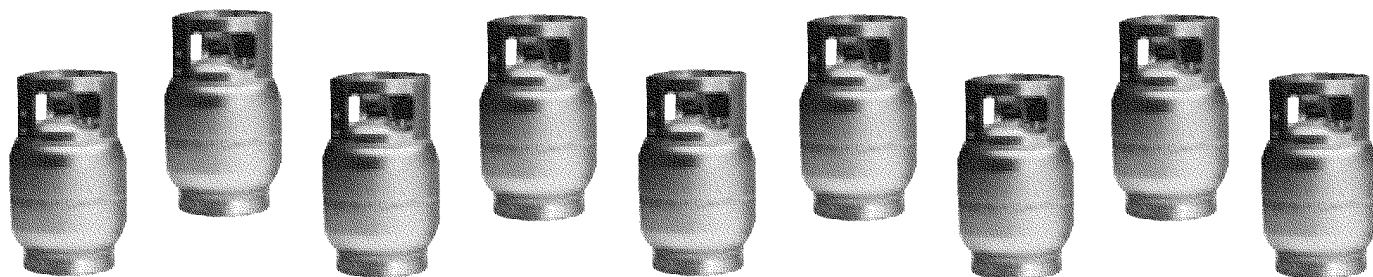

Liquefied petroleum gas (LPG) is a nonrenewable gaseous fossil fuel, which turns to liquid under moderate pressure. LPG, a by-product of natural gas processing and oil refining, includes various mixtures of hydrocarbons. The type of LPG used as a vehicle fuel is a liquid mixture containing at least 90 percent propane, 2.5 percent butane and higher hydrocarbons, and the balance ethane and propylene. The mixture is commonly called “propane.”

HISTORY

In 1910, under the direction of Dr. Walter Snelling, the U.S. Bureau of Mines investigated gasoline to see why it evaporated so fast and discovered that the evaporating gases were propane, butane, and other hydrocarbons. Dr. Snelling built a still that could separate the gasoline into its liquid and gaseous components and sold his propane patent to Frank Phillips, the founder of Phillips Petroleum Company.

By 1912, propane gas was cooking food in the home. The first car powered by propane ran in 1913. By 1915 propane was being used in torches to cut through metal. LPG has been used as a transportation fuel around the world for more than 60 years.

CURRENT USES

In the United States, LPG is currently the third most commonly used transportation fuel, ranked behind gasoline and diesel. It is also used for home barbecues, recreational vehicle appliances, and heating and cooking in areas where natural gas is not available.

In the United States, LPG has been used mostly in fleets, including school buses in Kansas and Oregon, taxicabs in Las Vegas, sheriff and police cars, and dozens of fleets throughout California. Many nonroad vehicles, such as industrial forklifts and farm vehicles, use propane. In Tokyo all taxis are required to run on propane to reduce urban smog. Other countries widely using LPG include Australia, Canada, the Netherlands, Italy, and Japan.

SOURCE, AVAILABILITY, AND PRICING

The United States is one of the world’s largest producers of LPG. Over 90 percent of the LPG used in the United States originates within the country. Texas is a major producer of LPG. An infrastructure for delivering propane is well established throughout the United States; publicly accessible fueling stations exist in all states. Propane prices are often tied to oil prices and tend to fluctuate widely. In areas where LPG is used as a heating fuel, seasonal rates during the winter season tend to increase LPG prices. Extended periods of unusually cold weather (“cold waves”) may cause sudden increases in the price of LPG.

STORAGE AND SAFETY

For storage and transportation, LPG is pressurized and LPG tanks are sealed. Sealed tanks eliminate evaporative emissions or spillage. Using outage valves incorrectly during refueling, however, could cause excess vapor discharge.

The weight of LPG vapors at ambient temperatures is approximately 150 percent the weight of air. If there is a leak, LPG vapors tend to sink to the ground and pool, creating a potentially hazardous situation. An odorant is added to make leaks more detectable. (In some areas in North America, LPG vehicles are not allowed in tunnels or in enclosed parking garages.)

Because LPG vaporizes when released from the tank and is not water soluble, LPG does not pollute underground water sources. LPG is extremely volatile and burns twice as hot as a gasoline fire. Vehicle fuel tanks in LPG vehicles are of relatively thick-wall steel construction. In the event of a vehicle crash, they are much less prone to rupture or to cause fires than gasoline tanks.

PERFORMANCE

Power, acceleration, payload, and cruise speed are comparable to those of an equivalent internal combustion engine. Propane has a high octane rating of 104 (compared with 87 for regular unleaded gasoline).

When introduced into a vehicle engine, LPG turns into a gas. In cold conditions, starting could be a problem because of the low vapor pressure of propane at low temperatures. A properly designed system enables quick starting in cold weather, however.

RANGE AND REFUELING

Refueling a propane vehicle is similar to filling a gas grill tank; the time it takes is comparable with that needed to fill a gasoline or diesel fuel tank. LPG refueling stations consist of a storage tank, a transfer pump, metering and dispensing equipment, and a hose. At the end of the hose is a coupling that connects to the coupling on the vehicle fuel tank. During refueling, the tank should be filled to no more than 80 percent capacity, to allow for liquid expansion as ambient temperature rises.

One gallon of LPG contains less energy than a gallon of gasoline. The driving range of a propane vehicle is about 86 percent that of a gasoline-powered vehicle. It takes 1.4 gallons of propane to provide the same amount of energy as one gallon of gasoline.

MAINTENANCE AND VEHICLE ALTERATIONS

Propane is stored on board in liquefied form under moderate pressure (about 200 pounds per square inch at 100°F). When it is drawn from the tank, it changes back into a gas before it is burned in the engine. Because it combusts in the gaseous phase, propane results in less corrosion and engine wear than does gasoline. Its high octane rating enables it to mix better with air and to burn more completely than does gasoline, generating less carbon. With less carbon buildup, spark plugs often last longer and oil changes are needed less frequently. According to the National Propane Gas Association, spark plugs from a propane vehicle last from 80,000 to 100,000 miles, and propane engines can last two to three times longer than gasoline or diesel engines.

EMISSIONS

Sealed tanks eliminate evaporative emissions or spillage. Refueling can be a source of LPG hydrocarbon emissions, however. Such emissions can be controlled through the use of special refueling valves. Certain toxics, especially benzene and butadiene, as well as regulated emissions, are generally lower than those of gasoline-fueled vehicles. Carbon dioxide emission levels are reduced by up to 40 percent over those of gasoline-fueled vehicles.

METHANOL

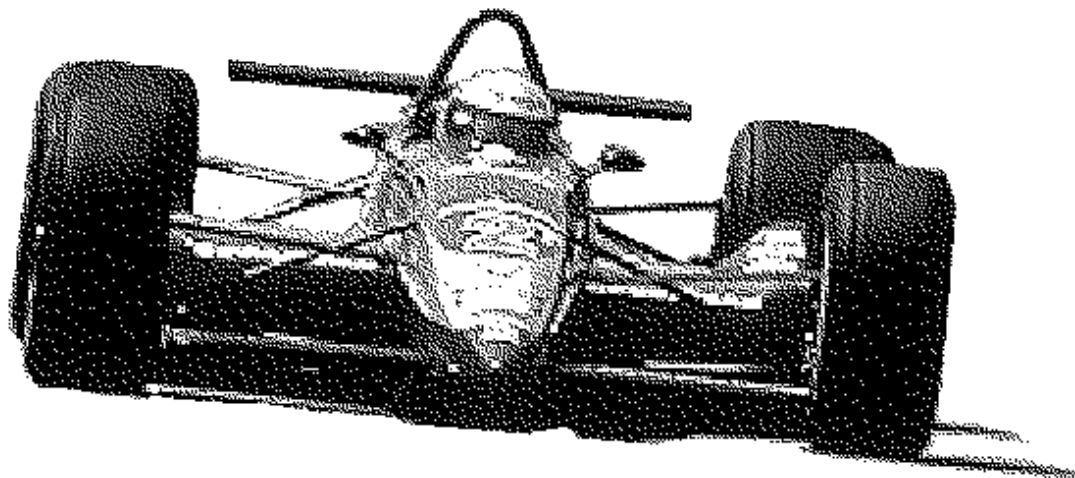

METHANOL

Methanol (CH_3OH) is a colorless, odorless, slightly flammable liquid, also called methyl alcohol or wood alcohol. Liquid methanol can be produced from just about anything containing carbon. Potential sources include natural gas, coal, and biomass. Currently most methanol is produced from natural gas, or methane, using steam, pressure, and a catalyst. Methane, a greenhouse gas, is also given off by decomposing vegetable matter in landfills — another source that could be tapped for methanol production.

HISTORY

Methanol was first discovered in 1823 by condensing gases from burning wood. Methanol has been used for more than 100 years as a solvent and as a chemical building block to make products such as plastics, plywood, and paint. It is also used directly in windshield-washer fluid and gas-line antifreeze, and as model airplane fuel.

CURRENT USES

Pure methanol (M100) has been used in heavy-duty trucks and transit buses equipped with compression-ignition diesel engines. Since 1965, M100 has been the official fuel for Indianapolis 500 race cars. (The last time gasoline was used in the Indianapolis 500 was in 1964, when the race suffered a pile-up of cars that resulted in a gasoline fire and deaths.) Typically, a blend of 85 percent methanol and 15 percent gasoline (M85) is used in cars and light trucks. Pure methanol can also be reformed in fuel cells into hydrogen, which is then used to power electric vehicles.

Methanol-powered vehicles have been found largely in the West, primarily in California. They can also be seen in the fleets of the federal government and the New York State Thruway Authority.

SOURCE, AVAILABILITY, AND PRICING

The United States produces almost one-quarter of the world's methanol supply. According to the American Methanol Institute (1998), about 75 percent of the methanol consumed in the United States is supplied by domestic chemical producers. The remaining supply comes from imports. Canada supplies about 13 percent, Trinidad, Venezuela, and Chile, 8 percent; Europe, Asia, and the Middle East, 2 percent; and the remaining 2 percent come from miscellaneous sources. If demand increased, methanol could probably be made less expensively abroad and delivered by ship to the United States.

STORAGE AND SAFETY

Because methanol is corrosive to some metals and damaging to rubber and some plastics, fuel storage tanks and dispensing equipment must be corrosion and damage resistant. California requires that underground storage tanks for methanol be double walled.

Because methanol is water soluble, it could be quickly diluted in large bodies of water to levels that are safe for organisms. Environmental recovery rates for methanol spills are often faster than for petroleum spills. As with gasoline, methanol can be fatal when ingested. Inhalation of fumes and direct contact with skin can also be harmful.

Because pure methanol flames are nearly invisible in daylight, gasoline is added as a safety precaution to provide color to a flame. Added gasoline also serves to add a smell to this otherwise odorless liquid. Because of its high flash point, methanol is less volatile than gasoline. It burns more slowly and at a lower temperature. Methanol is transported by barge, truck, or rail. In the event of an

accident, a pure methanol (M100) fire can be extinguished with water, while a M85 fire, because of the 15 percent gasoline content, cannot. (Water on gasoline spreads fires.)

PERFORMANCE

Power, acceleration, and payload are comparable with those of other fuels in equivalent internal combustion engines. M85 has a high octane rating of 102, compared with 87 for regular unleaded gasoline and 92 for premium unleaded; properly tuned vehicles may experience 7 to 10 percent higher horsepower.

Vehicles using methanol have difficulty starting in temperatures below 0°F. M85 includes 15 percent gasoline, which improves the starting ability in cold weather.

RANGE AND REFUELING

Methanol has about half the energy content of gasoline. With current engine technology, it takes about 1.64 to 1.7 gallons of M85 to go the same distance as with a gallon of gasoline. Because mileage using M85 is lower than mileage using gasoline, fueling is needed more frequently.

M85 can be dispensed from pumps in the same manner as gasoline or diesel. Because methanol is corrosive, however, fuel storage tanks and dispensing equipment must be corrosion resistant.

MAINTENANCE AND VEHICLE ALTERATIONS

Methanol is especially damaging to rubber and plastic parts. Parts that come in contact with the fuel need to be damage resistant. These include the fuel tank, fuel lines, fuel injectors, fuel pumps, and filters.

M85 is commonly used in fuel-flexible vehicles, which are specially designed to use combinations of methanol or regular unleaded gasoline stored in a single tank. The vehicles have a special sensor on the fuel line

that can detect the ratio of methanol to gasoline in the fuel tank. The sensor conveys this information to an onboard computer, which automatically adjusts the vehicle's fuel injection and ignition timing devices.

EMISSIONS

The methanol molecule has a simple chemical structure, which leads to clean combustion; reports from emissions studies, however, vary more widely for methanol than for other fuels probably because of differences among fuel blends used across the country and because vehicles may not be optimized for using methanol. Comparisons of M100 with gasoline and diesel have shown these results:

Carbon monoxide: Emissions vary — sometimes lower, but are usually equal or slightly higher.

Ground-level-ozone-forming potential: 30 to 60 percent less. (In order to take advantage of this characteristic, vehicles must be properly adjusted.)

Nonmethane evaporative hydrocarbons: Usually less.

Toxics: M100 contains none of the carcinogenic ingredients such as benzene, 1,3-butadiene, and acetaldehyde. M85 (with 15 percent gasoline) has 50 percent fewer toxic air pollutants than gasoline.

Formaldehyde levels: Much higher, although still low. The toxicity of formaldehyde is lower than that of other toxics, and formaldehyde emissions can be reduced dramatically with new technology, such as improved catalytic converters.

Nitrogen oxides: Usually comparable or less.

Greenhouse gases: Comparable to gasoline.

Particulate matter: Buses using M100 emit significantly less than diesel-fueled buses.



NATURAL GAS

Natural gas is a naturally occurring fossil fuel found by itself or near crude oil deposits in deep underground pockets. These pockets, formed by porous rock, are 3,000 to 15,000 feet below the earth's surface. Natural gas is not a petroleum product. It is a gaseous mixture of simple hydrocarbon compounds, primarily composed of methane (CH_4) with minor amounts of ethane, propane, butane, and pentane. Because the energy density of natural gas is low, when used as a fuel it is either compressed or liquefied by extreme cooling.

HISTORY AND CURRENT USES

In 1860, Etienne Lenoir of France developed and built an engine of a design practical for natural gas that ran on illuminating coal gas stored in a rubber bladder. Coal gas, a by-product of the production of coke, is made up largely of methane, the primary component of natural gas, and hydrogen. In 1862 Lenoir built a vehicle powered by one of his engines.

Natural gas now accounts for approximately one-fourth of the energy consumed in the United States. For many years it has been used reliably and efficiently in stationary internal combustion engines, supplying energy for commercial and industrial processes, home heating, and electricity generation. Many households use compressed natural gas for cooking and heating.

Natural gas vehicles are widely used in Italy, the former Soviet Union, New Zealand, Australia, Canada, Argentina, and the United States. Compressed natural gas (CNG) is used in vehicles of all weights and sizes; CNG fueling stations are located in most major cities and in many rural areas. Liquefied natural gas (LNG) is most suitably used by large trucks, locomotives, and transit buses; LNG is currently available through suppliers of cryogenic liquids.

SOURCE AND AVAILABILITY

There is a finite supply of natural gas. Natural gas currently used in the United States comes from domestic sources. At current levels of consumption, reserves are expected to last 120 years. An extensive network of natural gas pipelines can deliver fuel directly to many sites, including individual homes.

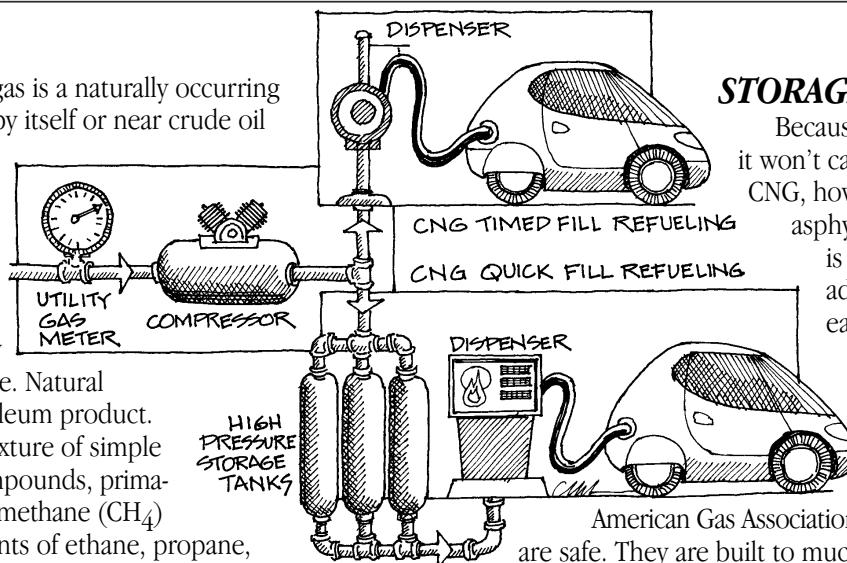

STORAGE AND SAFETY

Because natural gas is nontoxic, it won't cause injury; breathing of CNG, however, could cause asphyxiation. Since the fuel is odorless, odorants are added to make leaks easier to detect.

Sturdy, heavy tanks are used for safe high-pressure storage. According to the American Gas Association, CNG cylinders themselves are safe. They are built to much more rigorous standards than are gasoline tanks. During their development, they have undergone stringent tests, including being dropped from heights, exposed to explosions, being shot at with high-powered weapons, and burning in fires.

Danger to the environment is possible during extraction and processing, and through accidental releases of gas in distribution systems, fueling hook-ups, tank venting, or vehicle emissions. Mishaps can occur when corrosion causes the pressure-relief devices on fuel tanks to vent gas prematurely.

Gasoline and diesel fuels are heavier than air and stay near the surface. Natural gas is lighter than air and rises, a characteristic that creates a possible risk of explosion in enclosed areas. (LNG vehicles should never be parked indoors where possible ignition sources exist.)

PERFORMANCE

CNG burns more completely than gasoline and has a high octane rating of 130 (compared with 87 for regular unleaded gasoline). In a dedicated light-duty CNG vehicle, whose compression ratio is changed to take advantage of the higher octane rating, there may be up to a 10 percent increase in power. CNG also performs better than gasoline-powered vehicles under cold-start conditions.

The location and number of fuel cylinders may reduce the payload capacity, particularly in converted or dual-fuel vehicles.

RANGE AND REFUELING

When stored at a pressure of 3,600 psi, CNG provides about one-fourth the energy density of gasoline. The range of a CNG vehicle depends on the capacity to store fuel, but generally it is less than (about one-half) that of gasoline-fueled vehicles.

Refueling of CNG vehicles can be “slow” (generally taking six to eight hours and commonly done overnight) or “quick” (about five minutes, which is comparable with a gasoline fill-up). Overnight refueling is possible in individual homes with small compressors, which may be located in a home’s garage and connected to the natural gas supply of the house. Because of the gaseous nature of the fuel, the ambient air temperature can affect the amount of fuel that can be compressed into a tank. If a driver filled CNG cylinders on a hot afternoon, in the cool of the morning they might be only 75 to 85 percent full. CNG refueling dispensers are similar to gasoline or diesel dispensers, except the nozzles have positive-connect pressure fittings.

MAINTENANCE AND VEHICLE ALTERATIONS

Recommended maintenance schedules for CNG vehicles are similar to those for gasoline-fueled automobiles. Because CNG burns more cleanly than gasoline, CNG-powered vehicles require less maintenance, including fewer oil changes and less-frequent spark plug replacement. High-pressure tanks require periodic inspection.

Dedicated CNG vehicles are equipped with high-pressure storage tanks capable of storing natural gas at 3,000 psi to 3,600 psi. They are usually secured to the bottom of the vehicle. The gas travels from the tank through a high-pressure fuel line leading to the engine compartment. The gas is reduced to about 100 psi before being discharged or injected into the engine intake manifold and finally burned in the engine cylinders. These cylindrical tanks are constructed of high-strength steel, aluminum wrapped with a composite material, or all-composite materials. They are designed to withstand severe impact, high external temperatures, and environmental exposure.

EMISSIONS

CNG burns more completely than gasoline and emits lower amounts of all the regulated exhaust pollutants. Evaporative emissions are lower because CNG is stored in a sealed system. Carbon dioxide emissions are also lower than emissions from gasoline-powered vehicles, but methane levels are higher. Methane’s ability to trap heat in the atmosphere, or its global warming potential, is 21 times greater than that of carbon dioxide.

HOW A NATURAL GAS CAR WORKS

1. HIGH-PRESSURE CYLINDERS - are filled with compressed natural gas through a fill valve.

2. MASTER MANUAL SHUT-OFF VALVE - can stop the flow of natural gas through the high-pressure fuel line to the engine. When open, gas flows to the engine as needed.

3. REGULATOR - reduces gas pressure to approximately air pressure.

4. ENGINE - burns gas to create heat and convert it to mechanical energy. A solenoid valve controls gas flow into the engine through fuel injectors, as signaled by the accelerator pedal.

5. TRANSMISSION - carries the mechanical energy to the wheels.

6. RADIATOR - carries away waste heat and keeps the engine cool.

7. EXHAUST SYSTEM - has a muffler to soften the noise created by the explosion of the gas in the engine, and a tailpipe to carry away the exhaust from the occupants.

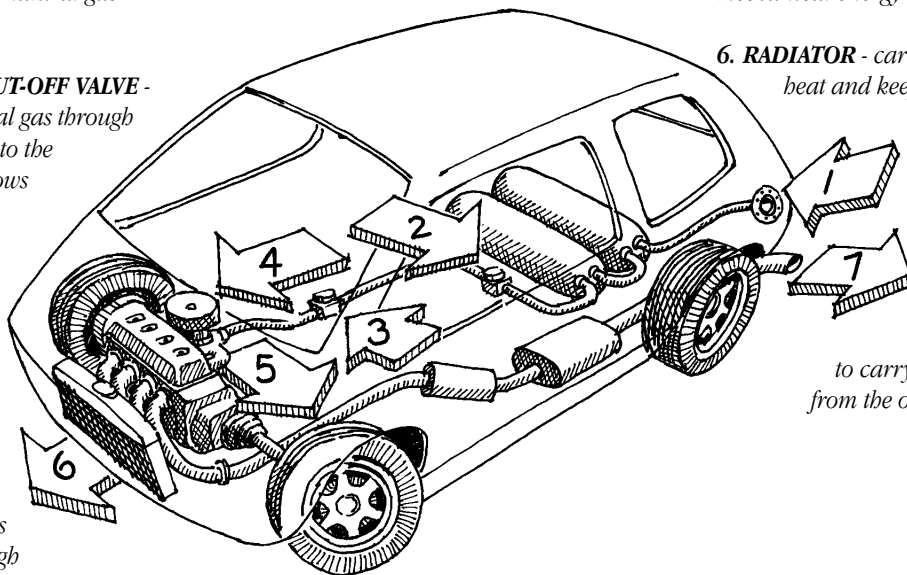

SOLAR ELECTRIC

Electric vehicles use electric motors instead of an internal combustion engine to provide motive force. Solar-powered vehicles (SPVs) use photovoltaic (PV) cells to convert sunlight into electricity. The electricity goes either directly to an electric motor powering the vehicle, or to a special storage battery. PV cells produce electricity only when the sun is shining. Without sunlight, a solar-powered car depends on electricity stored in its batteries.

HISTORY

Since the 1970s, inventors, government, and industry have invested their time, skill, and knowledge to develop solar-powered cars, boats, bicycles, and even airplanes.

In 1974, two brothers, Robert and Roland Boucher, flew an extremely lightweight, remote-controlled, pilotless aircraft to a height of 300 feet. It was powered by a PV array on the wings. In 1975 an improved version flew to 17,000 feet. (The U.S. Air Force funded the development of these aircraft with the hope of using them as spy planes.) In the early 1980s, Paul MacCready and his son developed a sun-powered plane, which crossed the English Channel at an average speed of 50 mph and a height of 12,000 feet. NASA supported the development of the "Pathfinder," a remote-controlled, 100-foot-long "flying wing" weighing less than 600 pounds. It is almost completely covered by a thin-film PV array. This PV system produces electricity to operate small motors, propellers, and flight control devices that move and steer the craft. The Pathfinder, with its ability to fly to altitudes as high as 80,000 feet, could be the precursor to solar-powered aircraft that can stay aloft for months as alternatives to space-based remote sensing satellites.

Perhaps the first totally solar-powered car was built by Ed Passerini, in 1977. It was small, lightweight, and cost relatively little. Solar cars equipped with advanced technology have been built with the backing of large automobile manufacturers, including General Motors (GM), Ford, and Honda.

CURRENT USES

Because solar cells produce electricity only when the sun is shining, SPVs are not practical for daily use. Most SPVs with built-on PV arrays are used only as research, development, and educational tools, and/or to participate in the various SPV races held around the world. These

races, such as the World Solar Challenge (Australia), the Tour de Sol (Switzerland), the American Tour de Sol, and the American Solar Cup, serve as proving grounds for new solar vehicle technologies, and help expose the public to the idea of solar energy as a power source. Students, engineers, and other inventors throughout the world compete in these races, often setting new records for distance, speed, or fuel efficiency.

PV cells are being used in some prototype EVs to extend their driving range. These are often referred to as solar-assist electric vehicles. In this case, the vehicle receives only a small amount of their electricity from solar energy, and uses conventional methods of recharging batteries.

SOURCES

Although solar energy is an unlimited resource, it is not always available when it's needed. To convert and store solar energy, an array of PV cells can be built onto the vehicle body itself, or fixed on a building or a vehicle shelter to charge the electric vehicle's battery while it is parked.

VEHICLE ALTERATIONS

SPVs that have a built-on PV array differ from conventional vehicles (and most EVs) in size, weight, and shape. The car must be extremely efficient. Lightweight structural materials, such as aluminum or lightweight composites, improve performance. They are usually built to carry very little — one or two people. Some use no batteries; others use lightweight silver-zinc batteries. The chassis of GM's Sunraycer, a prototype SPV that has won many solar car races, weighs only 14 pounds; the entire shell weighs less than 100 pounds; and the total weight of the vehicle, without the driver, is 390 pounds. While most developers use crystalline silicon PV cells, GM has used more efficient and more costly gallium arsenide cells.

A large amount of surface area is needed on the car to rely one hundred percent on solar power. The Sunraycer has a 90-square-foot curved solar array integrated into the teardrop-shaped body of the car. John Mitchell Systems designed an SPV with a PV array integrated into two vertical airfoils. These act as a sail to provide aerodynamic thrusts. (In tests, the vehicle achieved 30 miles per hour using wind power alone.) Ford and other auto companies have designed tiltable arrays that track the sun.

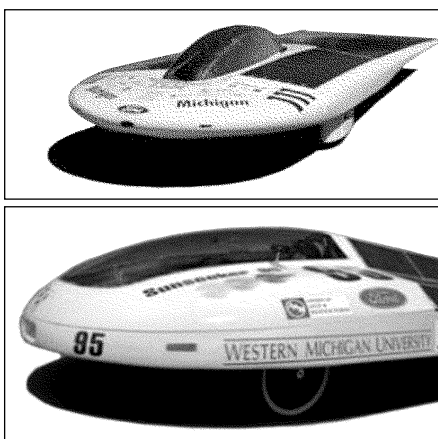

MAINTENANCE

Because an SPV has few moving parts, service requirements are less than for conventional cars. An SPV does not have an internal combustion engine, liquid fuel tank, fuel lines, carburetor, spark system, muffler, or pollution-control equipment. No timing belts, water pumps, radiators, fuel injectors, or tailpipes are required. No tune-ups, emissions-control adjustments, oil changes, or oil filter replacements are needed.

Lightweight silver-zinc batteries are expensive and need to be recycled after only a few charging cycles. Nickel-metal-hydride batteries may last up to 100,000 miles.

SAFETY

The primary safety concern with the development of a prototype vehicle or vehicle altered by hobbyists — as the majority of SPVs are — is that of design and an ability to adequately test the vehicle. If meant for road use, the final design must be road worthy. Proper attention must be paid to all aspects of vehicle design, including steering, suspension, breaks, rollover protection for the driver, proper seatbelts and seating, properly secured motors and batteries, and adequate chassis strength and durability. All prototypes and modified vehicles must be properly tested before operating on-road.

As with all electric vehicles, lethal levels of electricity may be present in the battery pack, so it should be treated with the same caution and respect as a full fuel tank in an internal combustion vehicle.

PERFORMANCE

The first American Solar Cup was held in September 1988 in Visalia, California, with the winning car clocking speeds up to 85 mph. Electric vehicles are very quiet.

RANGE AND RECHARGING

A vehicle completely covered with solar cells receives only a small amount of solar energy each day, and converts an even smaller amount of that to useful energy. State-of-the-art PV cells are only about 20 percent efficient.

The efficiency of solar cars is measured in watt-hours per mile, instead of miles per gallon. Efficient vehicles have traveled a mile on less energy than a 100-watt light bulb consumes in one hour. (For a gasoline-powered car to achieve comparable efficiency, it would need to get 500 miles per gallon.)

To store solar-generated electricity, some SPVs use silver-zinc batteries, which have both advantages and disadvantages when compared with lead-acid batteries. Silver-zinc batteries are lighter, are more efficient, and accept higher rates of charging. They are very expensive, however, and may be charged and discharged (cycled) only a few times before they become unusable and require recycling.

EMISSIONS

Of all the vehicle types, those relying on solar energy have the least impact on the environment. Since there is no internal combustion engine and no combustion takes place, there are no emissions. Added emissions are not produced by power plants, since SPVs do not rely on utility-generated electricity.

HOW A SOLAR-ASSIST ELECTRIC CAR WORKS

1. SOLAR PANELS -
(photovoltaic cells) convert sunlight to electricity.

2. COMPUTER -
decides whether to store electricity in the battery or send it directly to the motor:

3. ENERGY-STORAGE SYSTEM -
stores electricity until it is needed. The system may include batteries, supercapacitors, and/or a flywheel.

4. MOTOR CONTROLLER -
sends electricity smoothly and efficiently to the motor as needed. It is controlled by an accelerator pedal. If regenerative braking is installed, the controller will allow the motor to act as a generator and return braking energy to the energy-storage system.

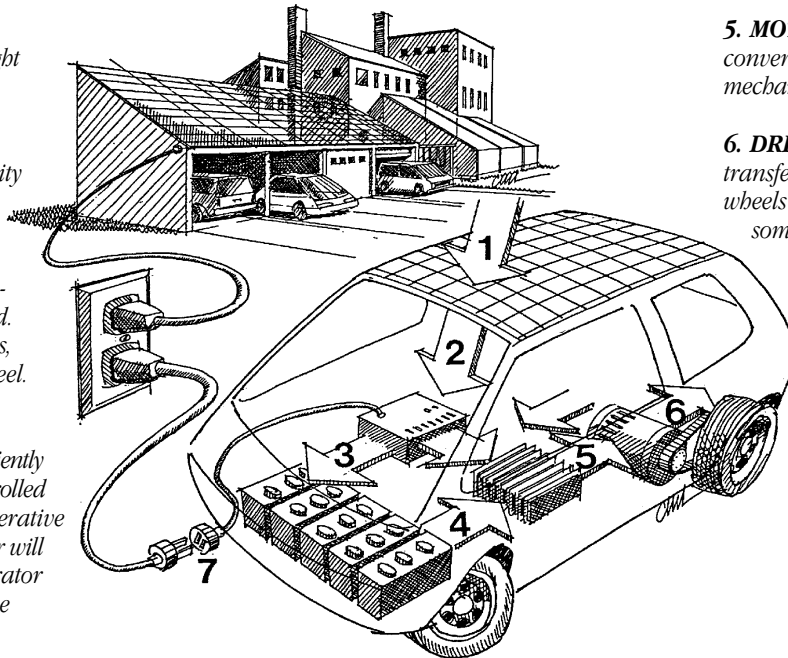

5. MOTOR -
converts electrical energy to mechanical energy and vice versa.

6. DRIVETRAIN -
transfers mechanical energy to wheels through a differential and sometimes a transmission.

7. GRID CONNECTION -
enables the energy-storage system to be charged by plugging into the grid or by home-mounted solar collectors. The charger may be on or off the vehicle.

RESOURCE GUIDE

RESOURCE GUIDE

This Resource Guide includes sources of information used in this unit and additional resources found on the web which may be useful to students and teachers doing research about alternative fuels. (This list is not comprehensive. Much information may be found on other sites and in periodicals, encyclopedias, and other publications in your library.) To save time for students who have limited access to the Internet, specific pages of web sites have been identified where information useful to this project can be found. (Please note that the Internet and website addresses are constantly changing.)

CONTENTS

Energy Information.....	89
Transportation in the United States.....	89
Air Quality and Health.....	90
Greenhouse Gases and Global Warming.....	90
Alternative Fuels, Miscellaneous.....	90
Battery Electric.....	92
Biodiesel.....	92
Electric Vehicles, Including Solar.....	93
Ethanol.....	93
Fuel Cells.....	94
Hybrid Electric.....	95
Hydrogen.....	95
Liquefied Petroleum Gas (Propane).....	96
Methanol.....	96
Natural Gas (CNG and LNG).....	96
Alternative Modes of Transportation.....	97

ENERGY INFORMATION

National Energy Information Center, U.S. Department of Energy

Energy Information Administration, EI 30
1000 Independence Avenue, SW, Washington, DC 20585
tel: (202) 586-8800
e-mail: infoetr@eia.doe.gov
URL: <http://www.eia.doe.gov>
Oil Consumption and Supplies
URL: <http://www.eia.doe.gov/emeu/iea/table12.html>
URL: <http://www.eia.doe.gov/emeu/iea/table81.html>

TRANSPORTATION IN THE UNITED STATES

Oak Ridge National Laboratory, U.S. Department of Energy

Center for Transportation Analysis, Oak Ridge, Tenn.
Publication: *Transportation Energy Data Book*
URL: <http://www.cta.ornl.gov/publications/tedb.html>

U.S. Department of Transportation

National Center for Statistics and Analysis, Washington, D.C.
tel: (202) 366-1503

AIR QUALITY AND HEALTH

American Lung Association

1726 M Street, N.W. Suite 902, Washington, DC 20036

(Also see your local ALA chapter.)

Publication: *State of the Air 2002 Report*

URL: <http://www.lungusa.org/air/>

California Air Resources Board: Public Information Office

2020 L Street, Sacramento, CA 95814

tel: (916) 322-2990

URL: <http://www.arb.ca.gov>

Offices of Air and Radiation, and Air Quality Planning and Standards, U.S. Environmental Protection Agency

Annual publication: *National Air Quality and Emissions Trends Report*, 1998 (Ch. 4: Criteria Pollutants–Nonattainment Areas)

URL: <http://www.epa.gov/air/urbanair/>

Publication: *Greenbook: Nonattainment Areas for Criteria Pollutants*

URL: <http://www.epa.gov/oar/oaqps/greenbk/>

Also see:

URL: <http://www.epa.gov/oar/aqtrnd97/brochure/>

URL: <http://www.epa.gov/oar/topics/comeap.html>

URL: <http://www.epa.gov/oar/oaqps/cleanair.html>

URL: <http://www.epa.gov/airs/criteria.html>

URL: <http://www.epa.gov/airnow/>

Office of Transportation and Air Quality, U.S. Environmental Protection Agency

2565 Plymouth Road, Ann Arbor, MI 48105

tel: (734) 214-4333

URL: <http://www.epa.gov/otaq/consumer.htm>

GREENHOUSE GASES AND GLOBAL WARMING

National Energy Information Center, U.S. Department of Energy

see Energy Information above

Report: *Carbon Dioxide Emissions from the Generation of Electric Power in the United States*, July 2000

URL: http://www.eia.doe.gov/cneaf/electricity/page/co2_report/co2report.html

U.S. Environmental Protection Agency

URL: <http://www.epa.gov/globalwarming/actions/transport/index.html>

URL: <http://www.epa.gov/oppeoe1/globalwarming/>

URL: <http://www.epa.gov/oar/topics/comeap.html>

ALTERNATIVE FUELS, MISCELLANEOUS

California Energy Commission: Transportation Technology Office

1516 Ninth Street, MS-41, Sacramento, CA 95814-5504

tel: (916) 654-4989

Publications: (916) 654-5200

fax: (916) 654-4420

e-mail: energia@energy.ca.gov

URL: <http://www.energy.ca.gov/afvs/>

Publication: *ABCs of AFVs: A Guide to Alternative Fuel Vehicles*, November 1999 (# 500-99-013. Cost: \$8.00)

URL: <http://www.energy.ca.gov/afvs/reports/ABCsintro.html>

Clean Cities, U.S. Department of Energy

P.O. Box 12316, Arlington, VA 22209
 hotline: 800-C-CITIES
 e-mail: ccities@nrel.gov
 URL: <http://www.ccities.doe.gov>
 URL: <http://www.ccities.doe.gov/success.shtml>

Publications:

Greening the Fleet: A Local Government Guide to Alternative Fuels and Vehicles, 1997
Guide to Alternative Fuel Vehicle Incentives & Laws, November 1996
Taking an Alternative Route: Fueling the Future

Clean Fuels Development Coalition

4641 Montgomery Avenue, Suite 350, Bethesda, MD 20814
 tel: (301) 718-0077
 fax: (301) 718-0606
 e-mail: cfdcinc@aol.com
 URL: <http://www.cleanfuelsdc.org>

National Renewable Energy Laboratory (NREL), U.S. Department of Energy

1617 Cole Blvd., Golden, CO 80401-3393
 The Alternative Fuels Data Center
 tel: (800) 423-1363
 URL: <http://www.afdc.nrel.gov/>
 e-mail: hotline@afdc.nrel.gov
 URL: <http://www.afdc.nrel.gov/questions.html>
 URL: <http://www.afdc.nrel.gov/refueling.html>
 Photographic Information Exchange
 URL: <http://www.nrel.gov/data/pix/>

Office of Transportation Technologies, U.S. Department of Energy

1000 Independence Avenue, SW, Washington, DC 20585
 tel: (202) 586-8072
 URL: <http://www.ott.doe.gov/technologies.shtml>
 URL: <http://www.afdc.doe.gov/>

Oak Ridge National Laboratory, U.S. Department of Energy

Publications Office (c/o Stacy C. Davis)
 P.O. Box 2008, Building 3156, MS-6073
 Oak Ridge, TN 37831-6073
 tel: (423) 574-5957
 fax: (423) 574-3851
 e-mail: DAVISSC@ornl.gov
 URL: <http://www.cta.ornl.gov>
 Annual publication: *Transportation Energy Data Book*
 URL: <http://www.cta.ornl.gov/Publications/Tedb.html>

Office of Transportation and Air Quality, U.S. Environmental Protection Agency

2565 Plymouth Road, Ann Arbor, MI 48105
 tel: (734) 214-4333
 URL: <http://www.epa.gov/otaq/fuels.htm>

BATTERY ELECTRIC

Argonne National Laboratory, U.S. Department of Energy

9700 S. Cass Avenue, Argonne, IL 60439

tel: (630) 252-2000

URL: <http://www.transportation.anl.gov/ttrdc/batteries/index.html> (brochure)

URL: <http://www.transportation.anl.gov/ttrdc/publications/>

URL: <http://www.transportation.anl.gov/ttrdc/publications/papers/saricks/sld009.html> (slide)

United States Council for Automotive Research, U.S. Advanced Battery Consortium(USABC)

330 Town Center Drive, Fairlane Plaza South, Dearborn, MI 48126

tel: (313) 248-4298

URL: <http://www.uscar.org/consortia&teams/consortiahompages/con-usabc.htm>

National Station Car Association

tel: (510) 839-6054

e-mail: stncar@ix.netcom.com

URL: <http://www.stncar.com>

URL: <http://www.stncar.com/toc.html>

URL: <http://www.stncar.com/conc.html>

Southern California Edison Company

Electric Transportation Department

2244 Walnut Grove Avenue, Rosemead, CA 91770

tel: (800) 483-4636 or (800) 4-EVINFO

BIODIESEL

Biodiesel Information Centre, Canadian Renewable Fuels Association

90 Woodlawn Road W, Guelph, Ontario. N1H 1B2

tel: (519) 767-0431

fax: (519) 837-1674

URL: <http://www.greenfuels.org/bioindex.html>

Energy Efficiency and Renewable Energy Clearinghouse (EREC)

P.O. Box 3048, Merrifield, VA 22116

tel: (800) DOE-EREC or (800) 363-3732

e-mail: doe.erec@nciinc.com

URL: <http://www.eren.doe.gov/consumerinfo/refbriefs/ta2.html>

URL: <http://www.eren.doe.gov/consumerinfo/afv.html>

National Biodiesel Board

P.O. Box 104898, 1907 Williams Street, Jefferson City, MO 65110

tel: (573) 635-3893 or (800) 841-5849

e-mail: info@nbb.org

URL: <http://www.biodiesel.org>

National Biofuels Program, U.S. Department of Energy

URL: <http://www.biofuels.doe.gov/biofuels.html>

URL: <http://www.ott.doe.gov/biofuels/>

URL: <http://www.eren.doe.gov/RE/bioenergy.html>

Office of Transportation Technologies, U.S. Department of Energy

1000 Independence Avenue, SW, Washington, DC 20585

tel: (202) 586-8072

URL: <http://www.afdc.doe.gov/altfuel/biodiesel.html>

ELECTRIC VEHICLES, INCLUDING SOLAR

Bay Area Action

265 Moffett Boulevard, Mountain View CA 94043-4723
 tel: (650) 625-1994
 URL: www.baaction.org/ev_project

Electric Vehicle Association of Canada

Suite 11, 21 Concourse Gate, Nepean, ON, Canada, K2E 7S4
 fax: (613) 723-8275
 e-mail: information@evac.ca
 URL: <http://www.evac.ca>

Electric Vehicle Association of the Americas

601 California St., Suite 502, San Francisco, CA 94108
 tel: (415) 249-2690 or (800) 4EV-FACT
 e-mail: ev@evaa.org
 URL: <http://www.evaa.org/evaa/pages/qfacts.html>

Electric Transit Vehicle Institute

1617-b Wilcox Boulevard, Chattanooga, TN 37404
 fax: (423) 622-0744
 email: etvi@vol.com
 URL: <http://www.etvi.org/>

CALSTART/WESTART

3360 E. Foothill Blvd., Pasadena, CA 91107
 tel: (626) 744-5600
 URL: <http://www.calstart.org>

Northeast Sustainable Energy Association (NESEA)

50 Miles Street, Greenfield, MA 01301
 tel: (413) 774-6051
 URL: <http://www.nesea.org/>

Pacific Gas and Electric (PG&E)

San Francisco, California
 tel: (800) 684-4648
 URL: <http://www.pge.com/cleanair/>
 URL: http://www.pge.com/003_save_energy/003b_bus/pdf/ev8pt6.pdf

Southern California Edison Company

Electric Transportation Department
 2244 Walnut Grove Avenue, Rosemead, CA 91770
 tel: (800) 438-4636

ETHANOL

Argonne National Laboratory, U.S. Department of Energy

see Battery Electric above
 URL: <http://www.transportation.anl.gov/ttrdc/fuels/index.html> (see Guidebook for Handling)
 URL: <http://www.transportation.anl.gov/ttrdc/publications/papers/saricks/sld009.html> (slide)

American Coalition for Ethanol

P.O. Box 85102, Sioux Falls, SD 57104
 tel: (605) 334-3381
 fax: (605) 334-3389
 URL: <http://www.ethanol.org/>
 URL: http://www.ethanol.org/information/ethanol_information.htm

Ethanol Information Center, Canadian Renewable Fuels Association

90 Woodlawn Road W., Guelph, Ontario. N1H 1B2
 tel: (519) 767-0431
 fax: (519) 837-1674
 URL: <http://www.greenfuels.org/ethindex.html>

National Biofuels Program, U.S. Department of Energy

URL: <http://www.biofuels.doe.gov/biofuels.html>
 URL: <http://www.ott.doe.gov/biofuels/>

Renewable Fuels Association

One Massachusetts Ave., NW, Suite 820, Washington, DC 20001
 tel: (202) 289-3835
 fax: (202) 289-7519
 e-mail: info@ethanolrfa.org
 URL: <http://www.ethanolrfa.org>
 URL: <http://www.ethanolrfa.org/outlook99/99industryoutlook.html>

FUEL CELLS

American Methanol Institute

800 Connecticut Ave., NW, Suite 620, Washington, DC 20006
 fax: (202) 331-9055
 e-mail: AMI@methanol.org
 URL: <http://www.methanol.org/fuelcell/>

Argonne National Laboratory, U.S. Department of Energy

see Battery Electric above
 URL: <http://www.transportation.anl.gov/ttrdc/fuelcell/index.html> (brochure)

Ballard Power Systems, Inc.

9000 Glenlyon Parkway, Burnaby, BC V5J 5J9
 tel: (604) 454-0900
 fax: (604) 412-4700
 URL: http://www.ballard.com/pem_intro.asp

Breakthrough Technologies Institute/Fuel Cells 2000

1625 K Street, NW, Suite 725, Washington, DC 20006
 tel: (202) 785-4222
 fax: (202) 785-4313
 URL: <http://www.fuelcells.org>

Fuel Cell Institute

P.O. Box 65481, Washington, DC 20035-5481
 tel: (301) 681-3532

Gas Technology Institute (GTI)

1700 South Mount Prospect Road, Des Plaines, IL 60018-1804

URL: <http://www.gri.org/>

Los Alamos National Laboratory, U.S. Department of Energy

"Fuel Cells at Los Alamos"

URL: <http://www.lanl.gov/worldview/science/features/fuelcell.html>

Publication: *Fuel Cells: Green Power* by Sharon Thomas and Marcia Zalbowitz

URL: <http://education.lanl.gov/resources/fuelcells/>

Union of Concerned Scientists

2 Brattle Square, Cambridge, MA 02238

tel: (617) 547-5552

e-mail: ucs@ucsusa.org

URL: <http://www.ucsusa.org>

HYBRID ELECTRIC

Argonne National Laboratory, U.S. Department of Energy

see Battery Electric above

URL: <http://www.transportation.anl.gov/ttrdc/publications/>

Office of Transportation Technologies, U.S. Department of Energy

URL: <http://www.ott.doe.gov/hev/>

Electric Transit Vehicle Institute

1617-b Wilcox Boulevard, Chattanooga, TN 37404

fax: (423) 622-0744

email: etvi@vol.com

URL: <http://www.etvi.org/>

Rocky Mountain Institute: Hypercar Center

1739 Snowmass Creek Road, Snowmass, CO 81654

tel: (303) 927-3851

URL: <http://www.hypercarcenter.org/>

HYDROGEN

Energy Efficiency and Renewable Energy Network, U.S. Department of Energy

Hydrogen Information Network

URL: <http://www.eren.doe.gov/hydrogen/>

URL: <http://www.eren.doe.gov/consumerinfo/refbriefs/a109.html>

National Hydrogen Association

1800 M Street, N.W., Suite 300, Washington, DC 20036-5802

tel: (202) 223-5547

fax: (202) 223-5537

URL: <http://www.hydrogenus.com/>

LIQUEFIED PETROLEUM GAS (PROPANE)

Argonne National Laboratory, U.S. Department of Energy

see Battery Electric above

URL: <http://www.transportation.anl.gov/ttrdc/publications/papers/saricks/sld009.html> (slide)

National Propane Gas Association

1600 Eisenhower Lane, Lisle, IL 60532-2167

tel: (630) 515-0600

fax: (630) 515-8774

e-mail: info@npga.org

URL: <http://www.npga.org>

URL: <http://www.npga.org/public/articles/index.html?Cat=7>

Ontario Propane Association

11-1155 North Service Road West, Oakville, ON, Canada L6M 3E3

tel: (905) 469-1941

fax: (905) 469-1942

URL: <http://www.propane.ca>

Propane Education and Research Council

1776 K Street, NW, Suite 204, Washington, DC 20006

tel: (202) 452-8975

fax: (202) 452-9054

URL: <http://www.propanecouncil.org>

Propane Vehicle Council

1130 Connecticut Ave. N.W., Suite 700, Washington, DC 20036

tel: (202) 530-0479

fax: (202) 223-0479

e-mail: vehicle@propanegas.com

URL: <http://www.propanegas.com/index.html>

URL: <http://www.propanegas.com/consumer/index.html>

METHANOL

American Methanol Institute

see Fuel Cells above

e-mail: AMI@methanol.org

URL: <http://www.methanol.org>

California Energy Commission, Transportation Technology and Fuels Office

see Alternative Fuels above

URL: <http://www.energy.ca.gov/afvs/>

NATURAL GAS (CNG AND LNG)

American Gas Association

1515 Wilson Blvd., Arlington, VA 22209

tel: (703) 841-8000

URL: <http://www.aga.org>

URL: <http://www.fuelingthefuture.org/contents/NaturalGasVehicles.asp/>

Argonne National Laboratory, U.S. Department of Energy

see Battery Electric above

URL: <http://www.transportation.anl.gov/ttrdc/publications/papers/saricks/sld009.html> (slide)

CALSTART-WESTART

see Electric Vehicles above

URL: <http://www.calstart.org/afvscom.html>

The EnergySource Network

tel: (480) 377-8800

URL: http://www.energysource.com/energyexperts/natural_gas_facts/index.html

Natural Fuels Company, LLC

5855 Stapleton Drive North, Denver, CO 80216-3312

tel: (303) 322-4600 or (800) 366-4602

fax: (303) 322-4622

e-mail: jgonzales@naturalfuels.com

URL: <http://www.naturalfuels.com>

URL: http://www.naturalfuels.com/q_and_a.htm

The Natural Gas Vehicle Coalition

1100 Wilson Blvd., Suite 850, Arlington, VA 22209

tel: (703) 527-3022

fax: (703) 527-3025

URL: <http://www.ngvc.org>

URL: <http://www.ngvc.org/qa.html#work>

URL: <http://www.ngvc.org/ngvs.html>

Pacific Gas and Electric Company (PG&E)

see Electric Vehicles above

URL: <http://www.pge.com/cleanair/>

URL: http://www.pge.com/003_save_energy/003b_bus/003b3a2_gas_veh.shtml

ALTERNATIVE MODES OF TRANSPORTATION

Bicycle Awareness Program, California Air Resources Board

P.O. Box 2815, Sacramento, CA 95812-2815

tel: (916) 322-7062

fax: (916) 322-3646

Center of Excellence for Sustainable Development, U.S. Department of Energy

Sustainable Transportation Success Stories:

URL: <http://www.sustainable.doe.gov/transprt/trsstoc.shtml>

NOTES

NOTES

NOTES

NOTES