



Junior Solar Sprint Model Race Car Design & Construction Instructions

http://www.nrel.gov/education/jss_hfc.html

Making the Chassis

Step 1

- Using a No. 2 pencil, draw **Line A** down the center of a balsa sheet.

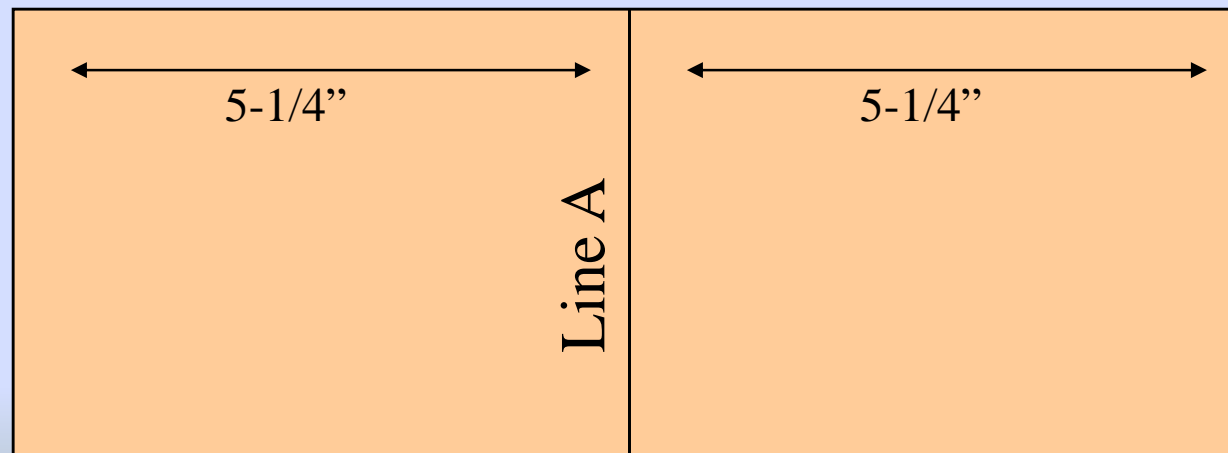

Making the Chassis

Step 2

- Turn over the balsa sheet and draw **Line B** $\frac{3}{4}$ " from one end of the sheet.



Making the Chassis

Step 3

- Draw a $5/8$ " x $1-1/2$ " notch 1" from the top of the sheet.



Making the Chassis

Step 4

- Draw **Line C** 2-1/2" from the other end of the same sheet of balsa.



Making the Chassis

Step 5

- Using a sharp utility knife or a coping saw, cut out the notch drawn in Step 3. **Save the cut out piece of balsa for a later step.**

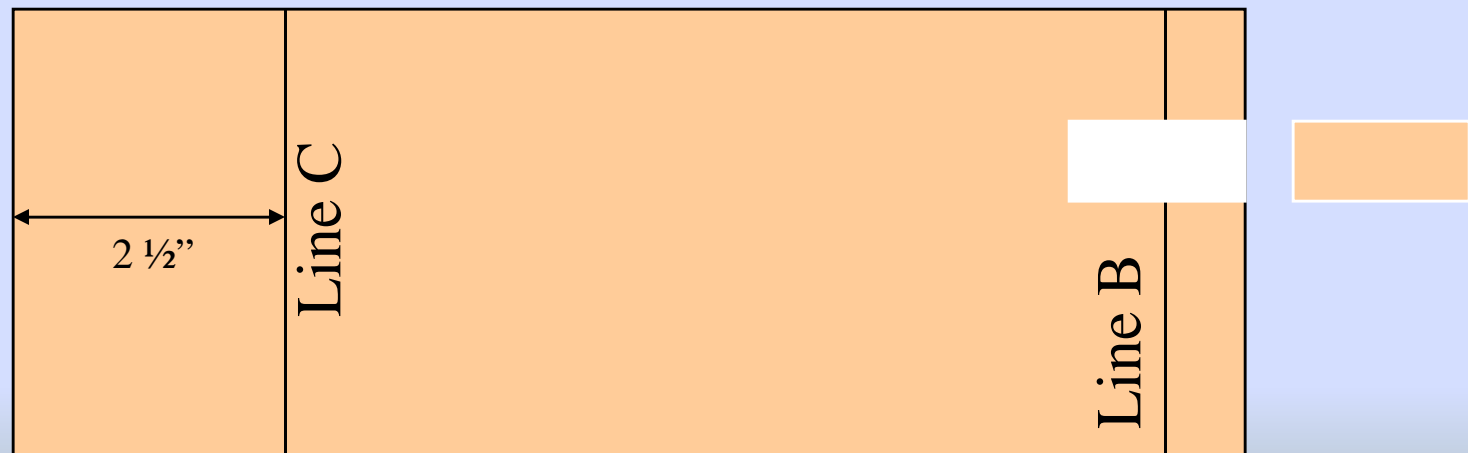

Making the Chassis

Step 6

- Locate the other sheet of balsa and draw a line 1-1/8" from one of the narrow ends. Cut along the line to produce a 1-1/8"x4" **panel support member**.

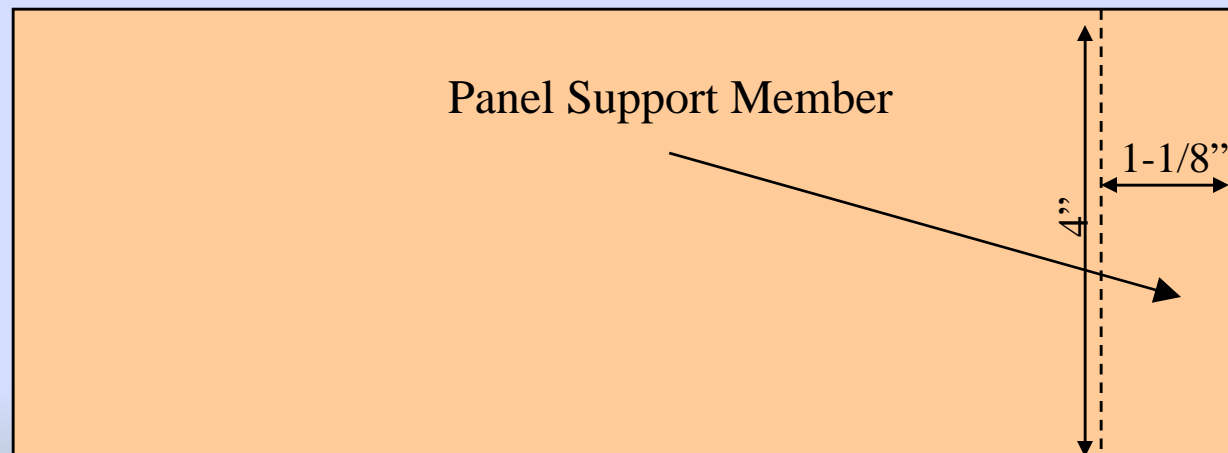

Making the Chassis

Step 7

- Using a cool-melt glue gun, run a small bead of glue along one of the 4” edges of the panel support member and attach firmly at **Line A**. After it is in place, run an additional bead of glue on each side of the joint between the chassis and the support member.

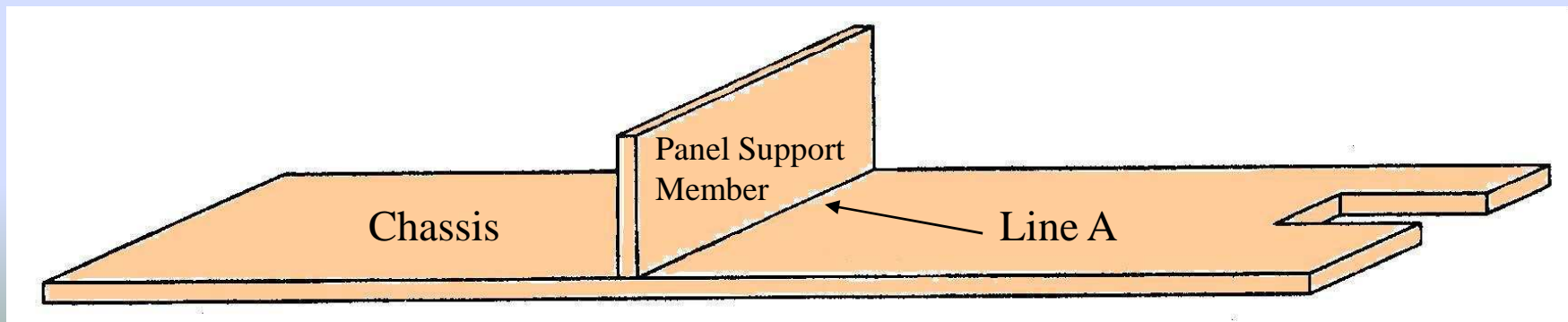

Wheels, Gears, and Axles

Note:

Installing wheels and gears on axles can be difficult. Be careful not to bend the Delrin axle.

To ease the process, insert a 1/8" drill bit through the holes. The gears and wheels should fit snugly to the axle and provide power to the wheels.

Rear Axle Assembly

Step 1

- Locate the plastic gear font and detach **Gear D** from the font. (A letter can be found on the back of each gear)

Gear D

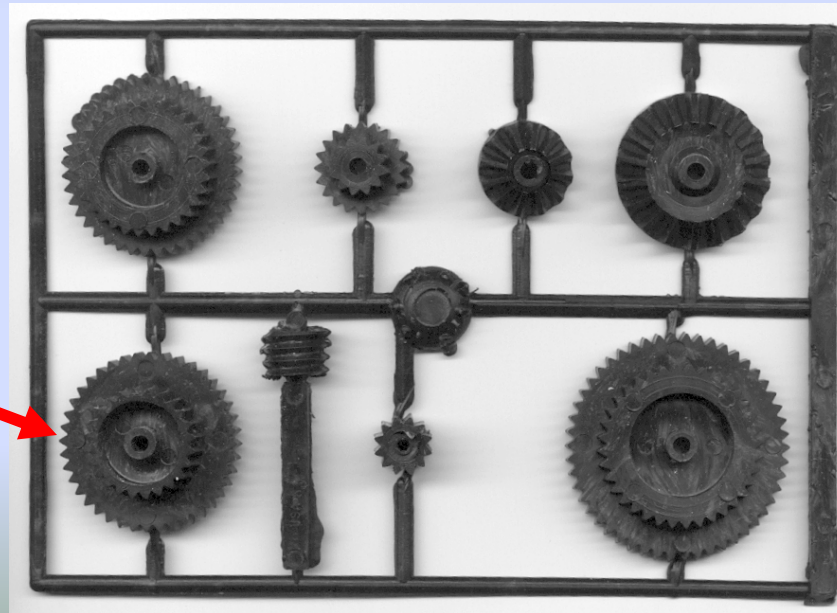
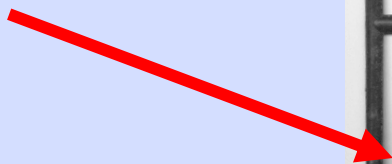

Rear Axle Assembly

Step 2

- Inspect the gear and, using a sharp knife, carefully remove any plastic flashing between the gear teeth.

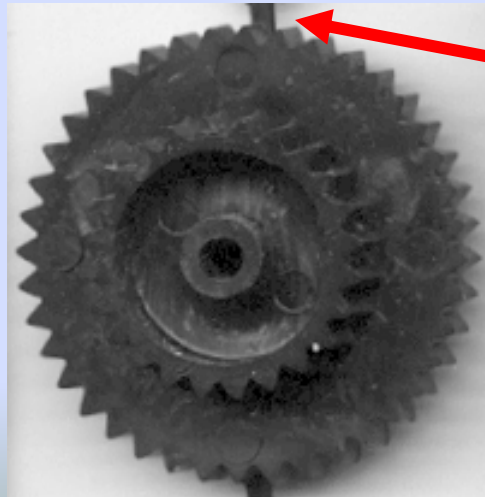

Plastic Flashing

Rear Axle Assembly

Step 3

- Place the gear on a table with the smaller gear face up and insert one of the Delrin axles into the gear.

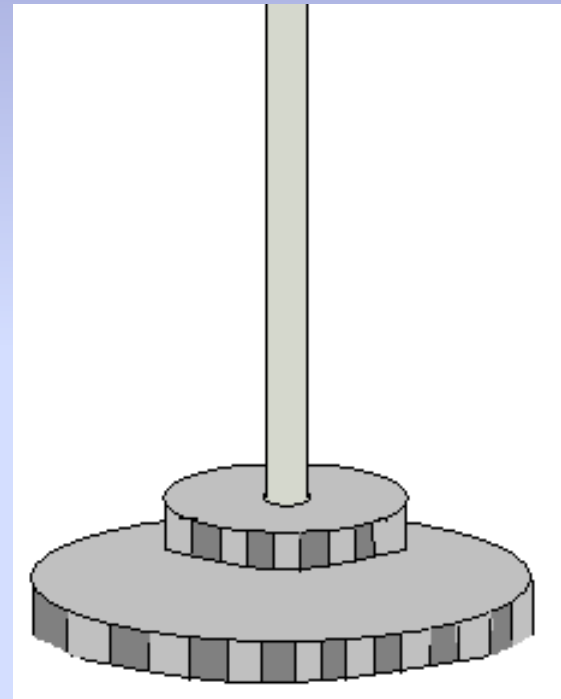

Rear Axle Assembly

Step 4

- Carefully slide the gear $1\frac{7}{8}$ " from one end of the axle. It should be $3\frac{1}{4}$ " from the other end of the axle.

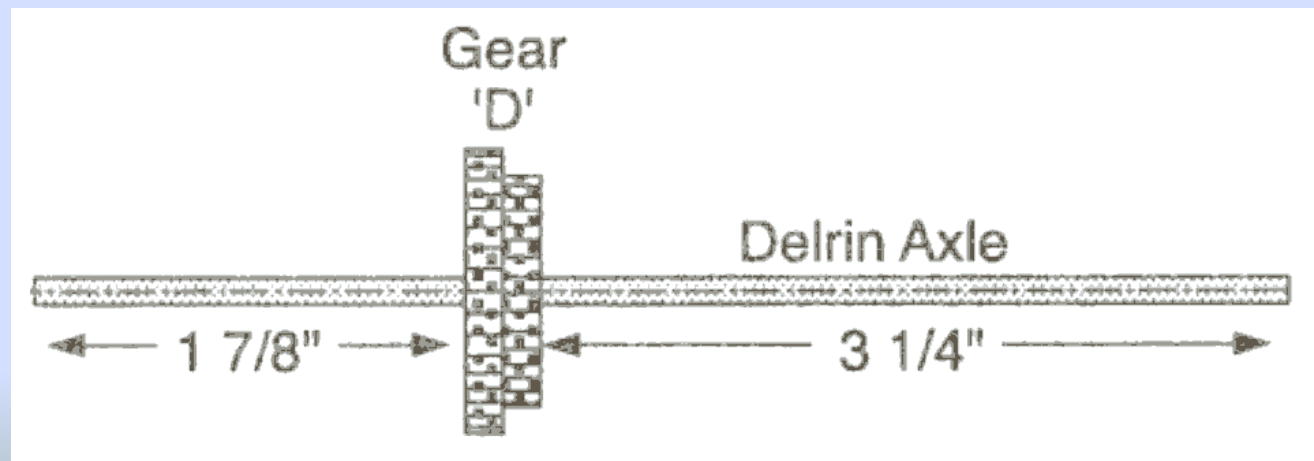

Rear Axle Assembly

Step 5

- Slide two nylon spacers onto the axle, one on each side of the gear.

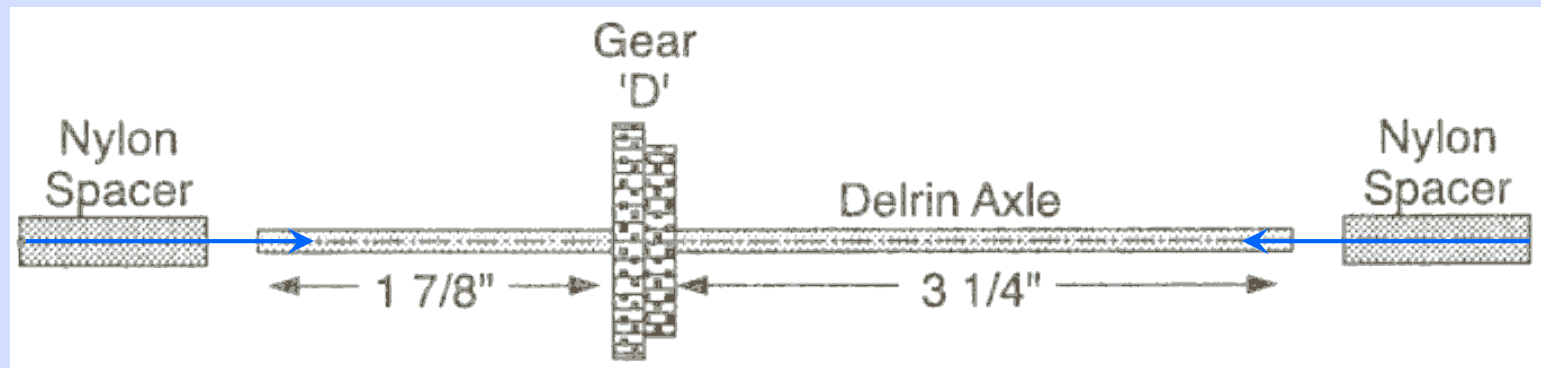

Rear Axle Assembly

Step 6

- Place one of the wide plastic wheels flat on a table. Keeping the spacers in place, insert one end of the axle into the wheel. Slide the axle into the wheel until it is flush with the opposite side of the wheel.

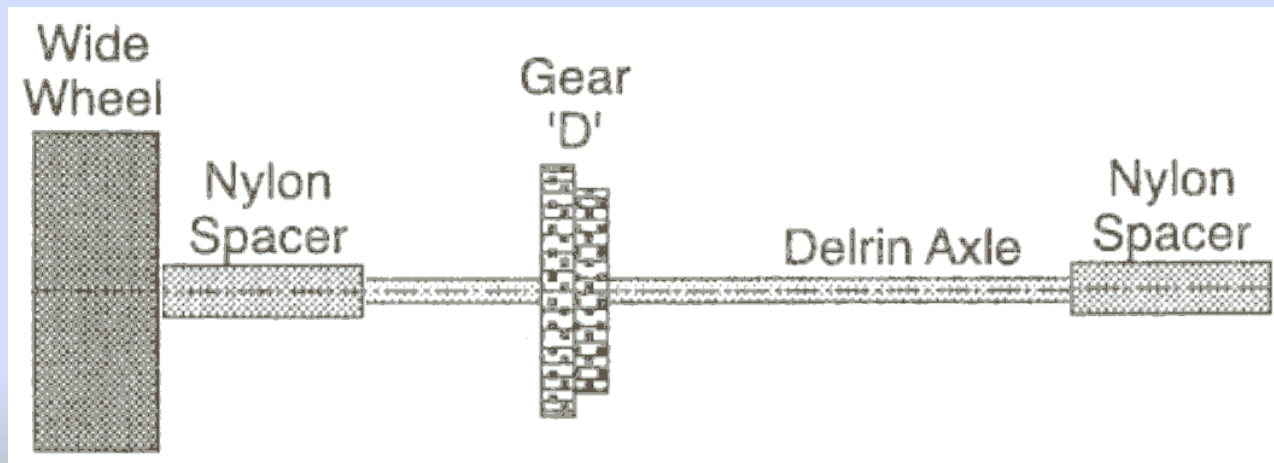

Rear Axle Assembly

Step 7

- Lay the other wide plastic wheel flat on the table. With spacers still in place, slide the free end of the axle into the wheel until it, too, is flush with the opposite side of the wheel.

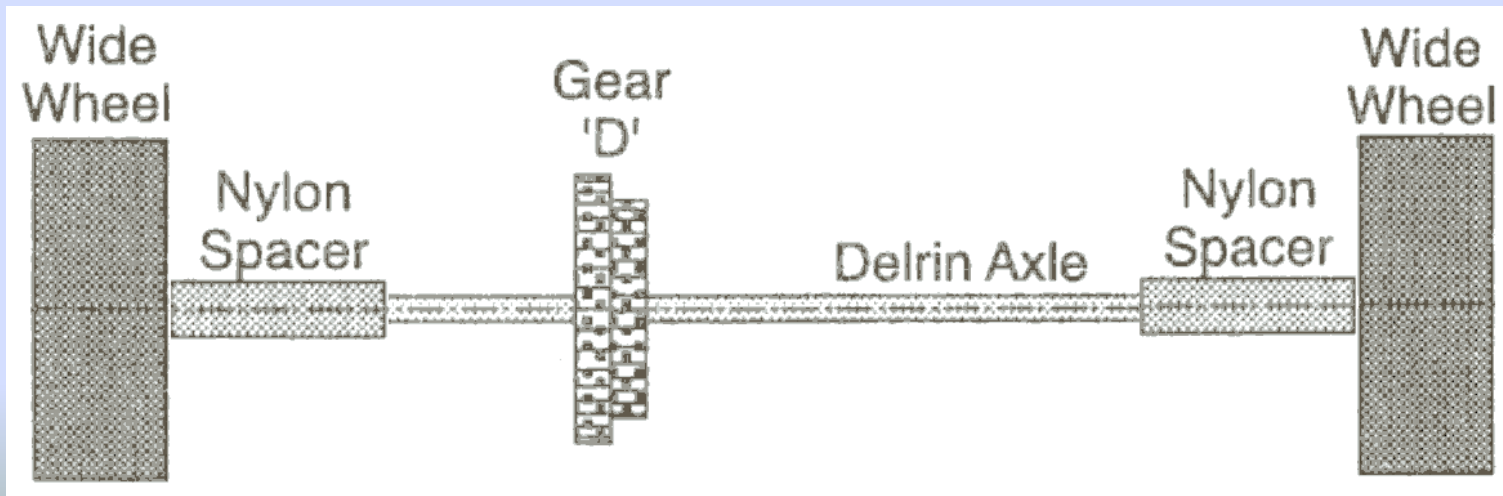

Rear Axle Assembly

Step 8

- Stretch a wide rubber band around each of the wide wheels. These act as tires and provide traction for your vehicle.

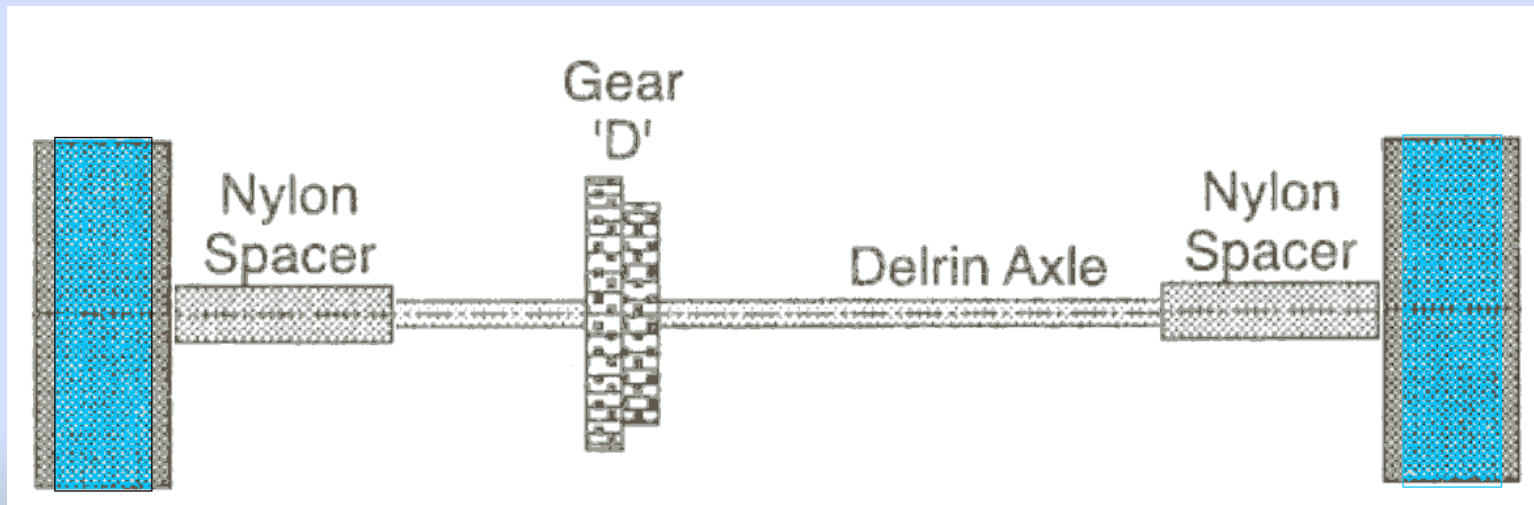

Front Axle Assembly

Step 1

- Place one of the two thin wheels flat on the table. Insert one end of the remaining Delrin axle into the wheel until the end of the axle is flush with the opposite side of the wheel.



Front Axle Assembly

Steps 2 & 3

- Slide two nylon spacers onto the free end of the axle. While keeping the spacers on the axle shaft, slide the free end of the axle into the other thin wheel until the end of the axle is flush with the opposite side of the wheel.

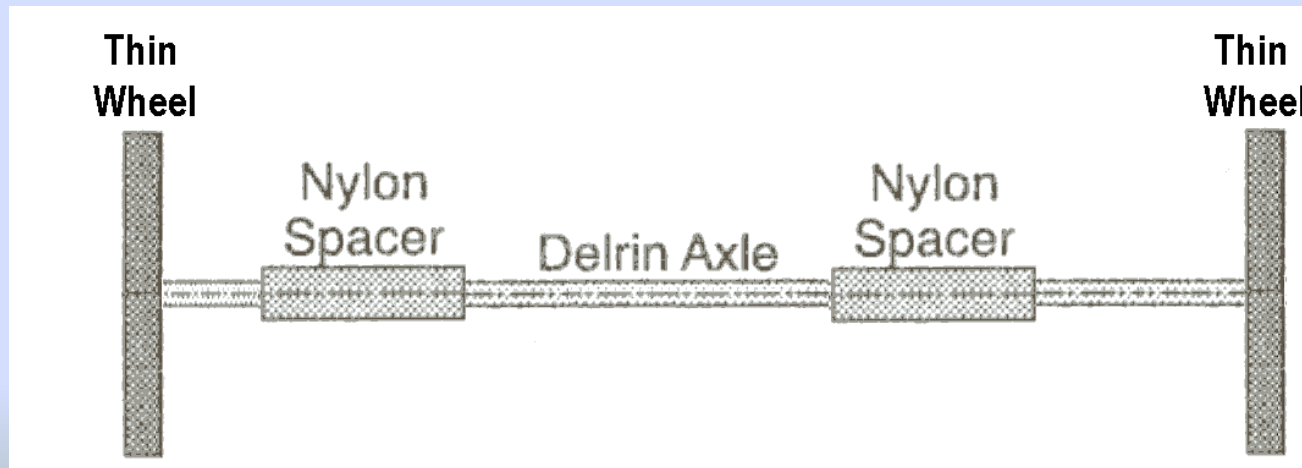

Attaching Axle Assemblies to Chassis

Step 1

- Position the notched chassis on the table so that the notched end of the balsa is hanging over the table edge, and **Lines B and C** are shown.



Attaching Axle Assemblies to Chassis

Step 2

- Carefully position the rear axle assembly so that:
 - **Gear D** is centered in the notched area of the chassis.
 - The axle is positioned along **Line B** between the line and the end of the chassis.
 - The nylon spacers are positioned within 1/16" of each wheel.

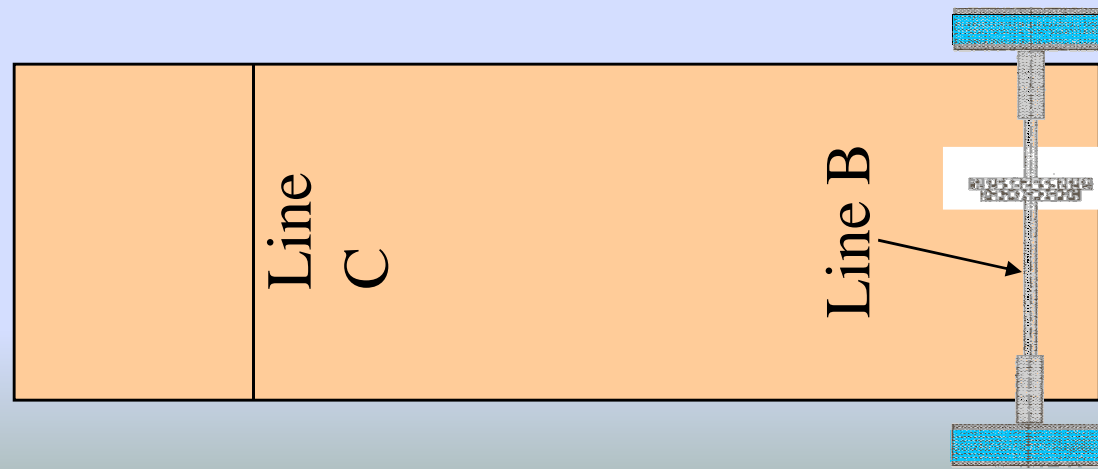

Attaching Axle Assemblies to Chassis

Step 3, 4 & 5

- When the rear axle is positioned as described in Step 2, use small C-clamps or ask a friend to hold the rear axle assembly in the correct position.
- While the rear axle is in the correct position, gently apply a bead of cool-melt glue along the sides of the nylon spacers where they contact the chassis.
- Hold the rear axle assembly in place until the glue cools.

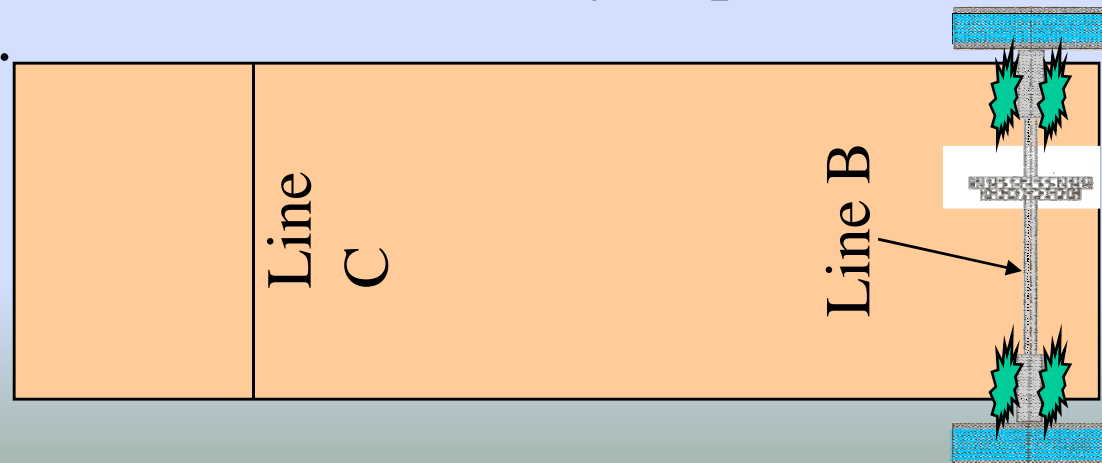

Attaching Axle Assemblies to Chassis

Steps 6 & 7

- Place the front axle assembly along **Line C** between the line and the rear axle assembly.
- Position the axle so that the wheels are equidistant from the chassis.

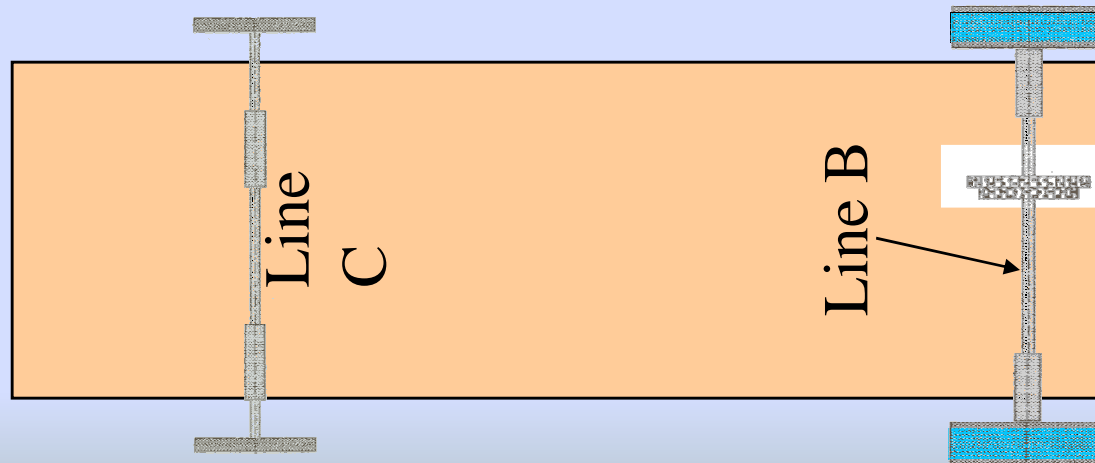

Attaching Axle Assemblies to Chassis

Steps 8, 9 & 10

- Slide the spacers to within 1/16" of each wheel.
- Hold the assembly in place and gently apply a bead of cool-melt glue along the sides of the nylon spacers where they contact the chassis.
- Hold the front axle assembly until the glue dries.

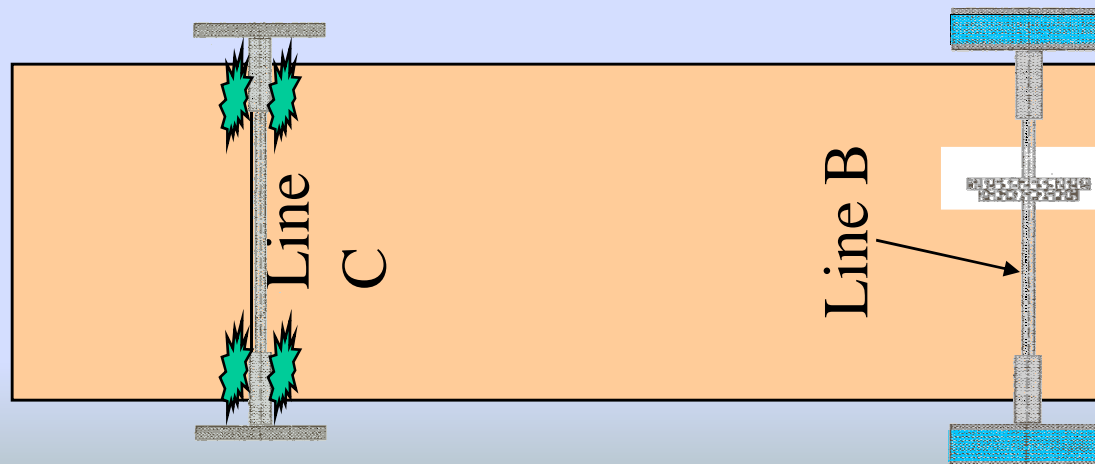

Attaching Motor Assembly to Chassis

Steps 1 & 2

- Find the spur gear (**Gear A**) on the plastic gear font.
- Remove Gear A from the font and cut off any excess plastic between the teeth of the gear.

Gear A

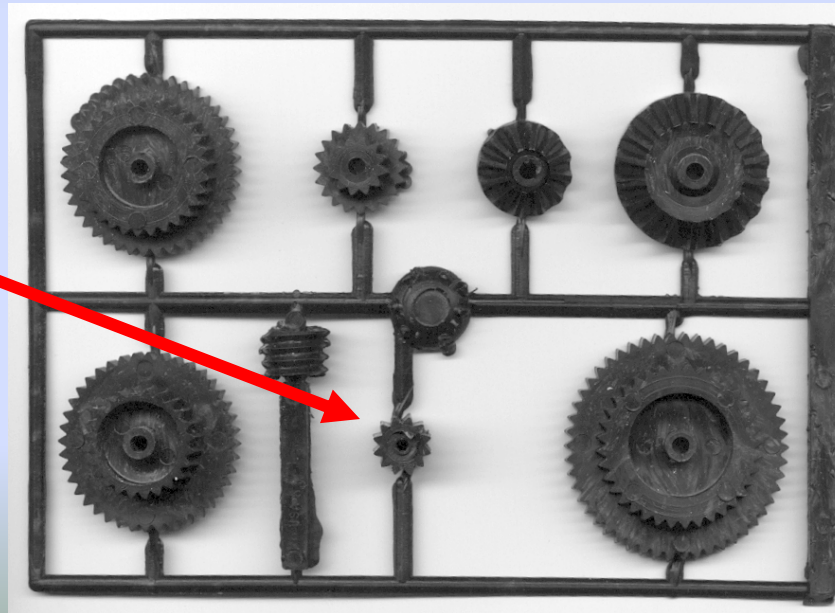

Attaching Motor Assembly to Chassis

Step 3

- Insert the shaft of the motor into **Gear A** to within 1/8" of the body of the motor.

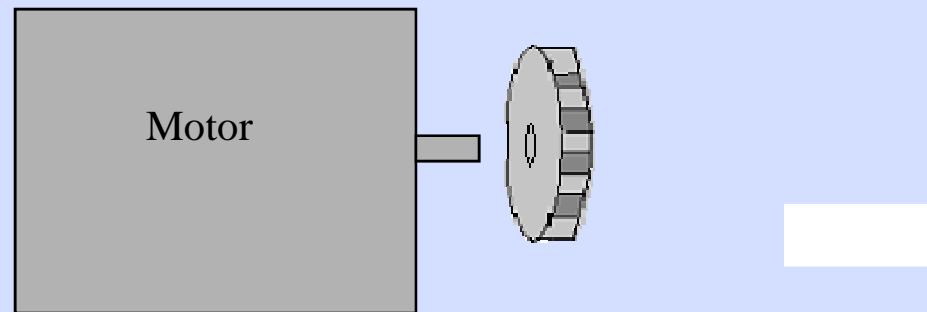

Attaching Motor Assembly to Chassis

Step 4

- Set the chassis on the table with the axle assemblies facing down.

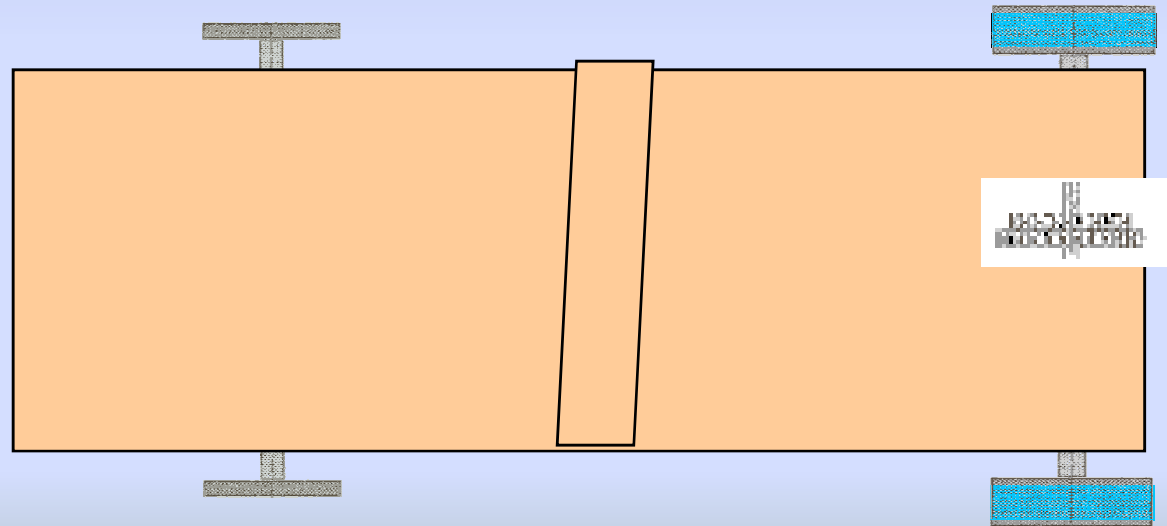

Attaching Motor Assembly to Chassis

Step 5

- Using a cool-melt glue gun, create a $\frac{1}{2}$ " x 1" rectangle of glue about $\frac{1}{8}$ " deep in the larger area to the side of the notch.

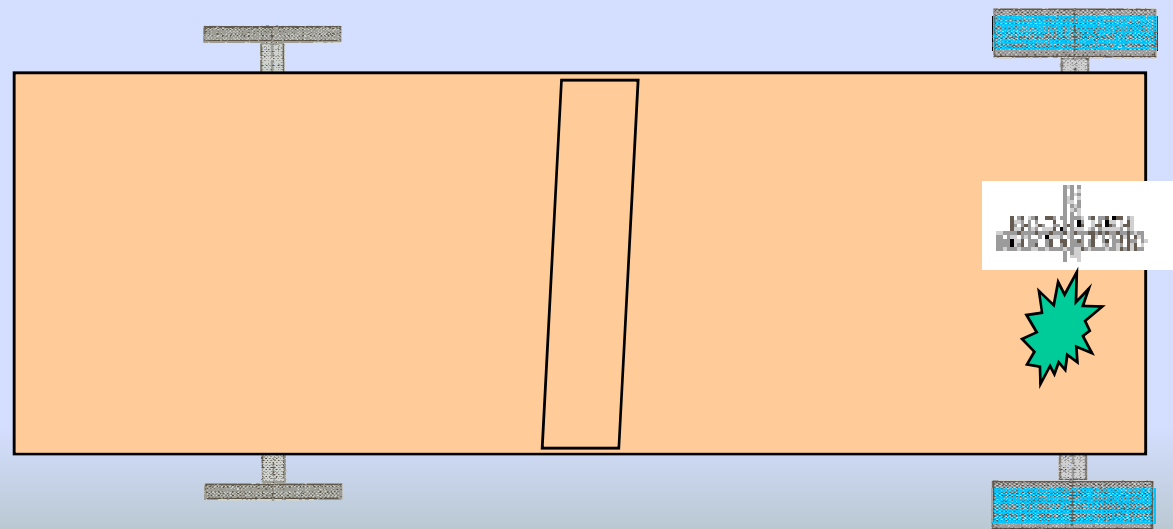

Attaching Motor Assembly to Chassis

Steps 6 & 7

- While the glue is still liquid, place the motor on its side (with vent holes up) on the glue so that **Gear A** sits directly on top of and engages **Gear D**. Be sure not to obstruct or fill the vent holes with glue.
- Hold the motor in place while the glue cools.

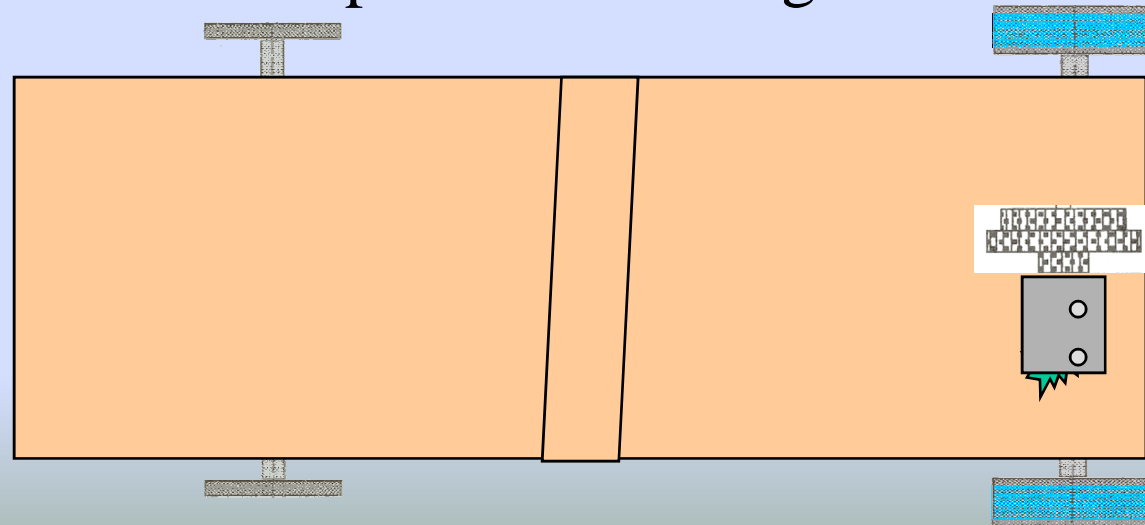

Attaching Motor Assembly to Chassis

Step 8

- Locate the small piece of balsa you saved when you cut out the notch from the chassis. Apply cool-melt glue to one side of the balsa piece. Press it into place on the chassis directly in front of the motor. This will keep the motor in place if the vehicle comes to a sudden stop (crashes).

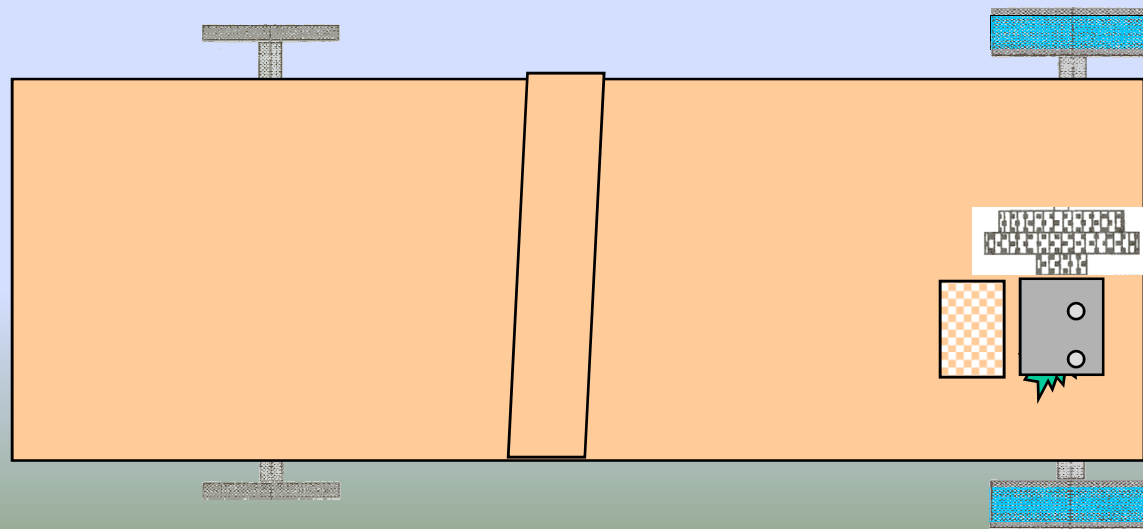

Attaching Motor Assembly to Chassis

Step 9

- If the motor dislodges, use the tip of the glue gun to soften the glue on the chassis where the motor was. Add a small amount of glue and reattach the motor as you did before.

Solar Panel Assembly

Step 1

- Connect the alligator clips to the leads on the solar panel.
 - A. Insert one of the two leads through the small hole in an alligator clip.

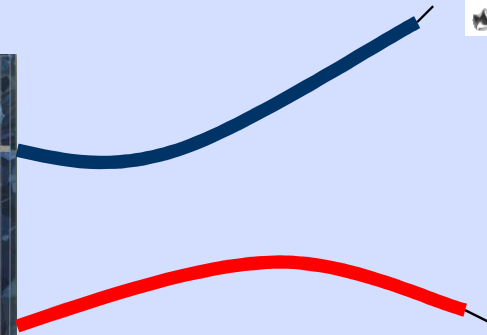
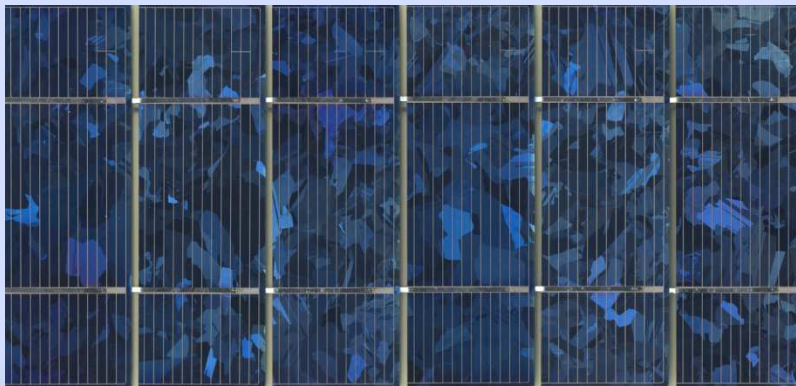

Solar Panel Assembly

Step 1 (continued)

- Connect the alligator clips to the leads on the solar panel.
 - B.** Using a pair of pliers, bend the tabs on the alligator clip over the lead.

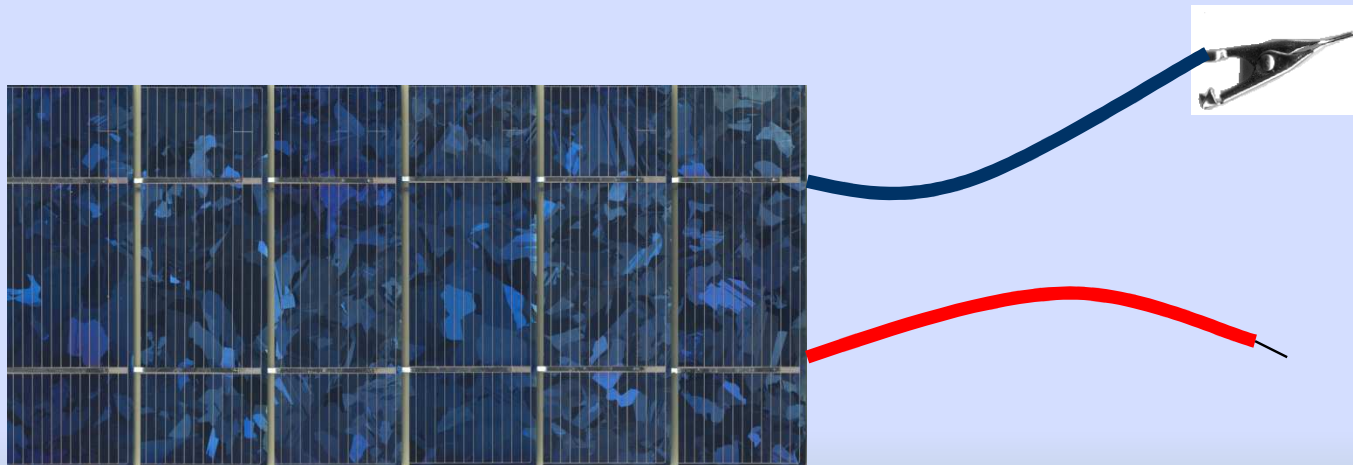

Solar Panel Assembly

Step 1 (continued)

- Connect the alligator clips to the leads on the solar panel.
 - A. Strip the insulation from the leads.
 - B. Solder the leads to the clips.
 - C. Solder the lead to the alligator clip. Be sure to heat the metal around the lead thoroughly so solder flows freely and attaches to the clip.

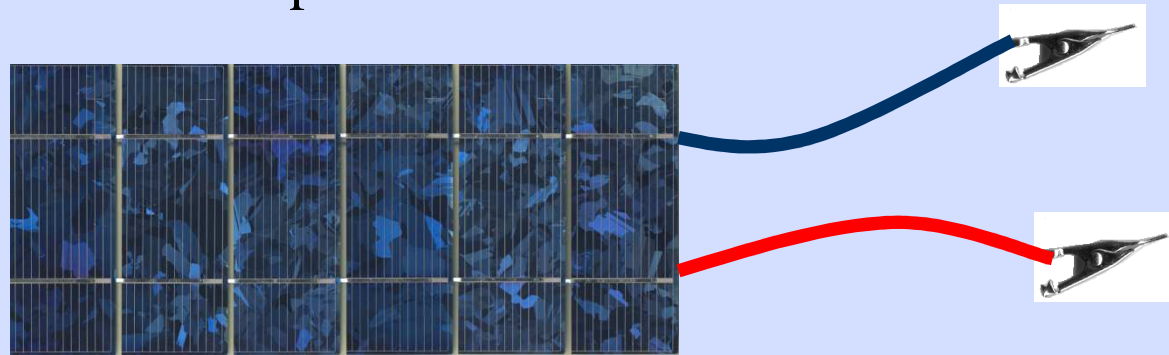

Step 2

- Repeat step one for the second lead of the panel

Final Assembly

Step 1

- Using a cool-melt glue gun, run a small bead of glue on the top, extreme front of the chassis. Allow the glue to cool. This will provide a ledge for the solar panel or solar panel blank to rest.

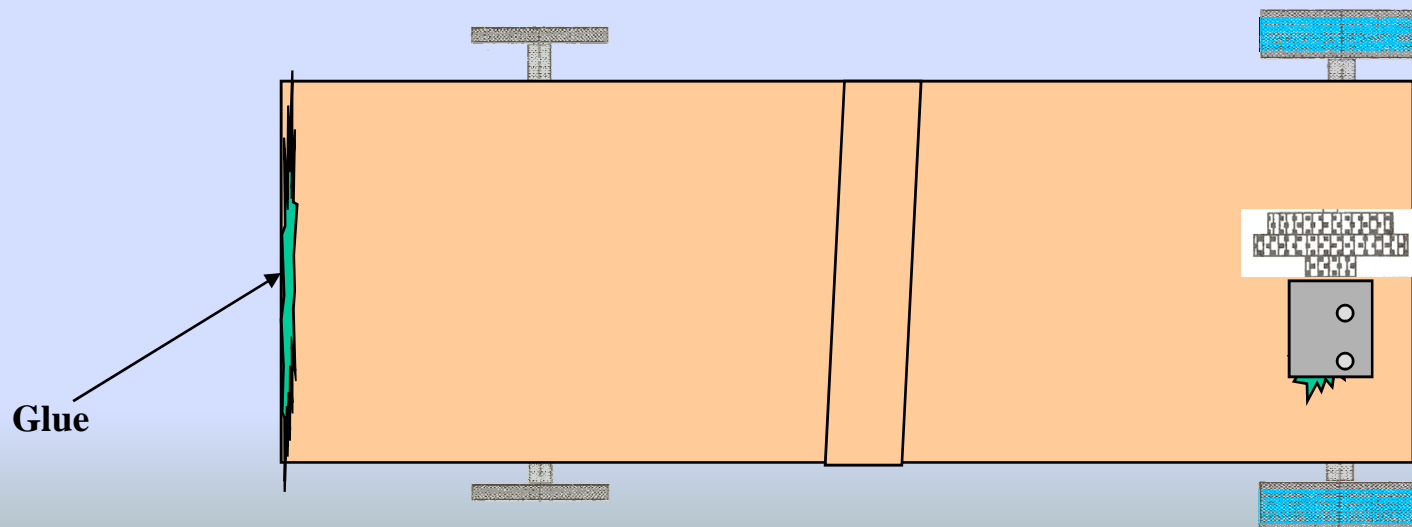

Final Assembly

Step 2

- Run another bead of glue along the front edge of the chassis to provide a bumper for your vehicle.

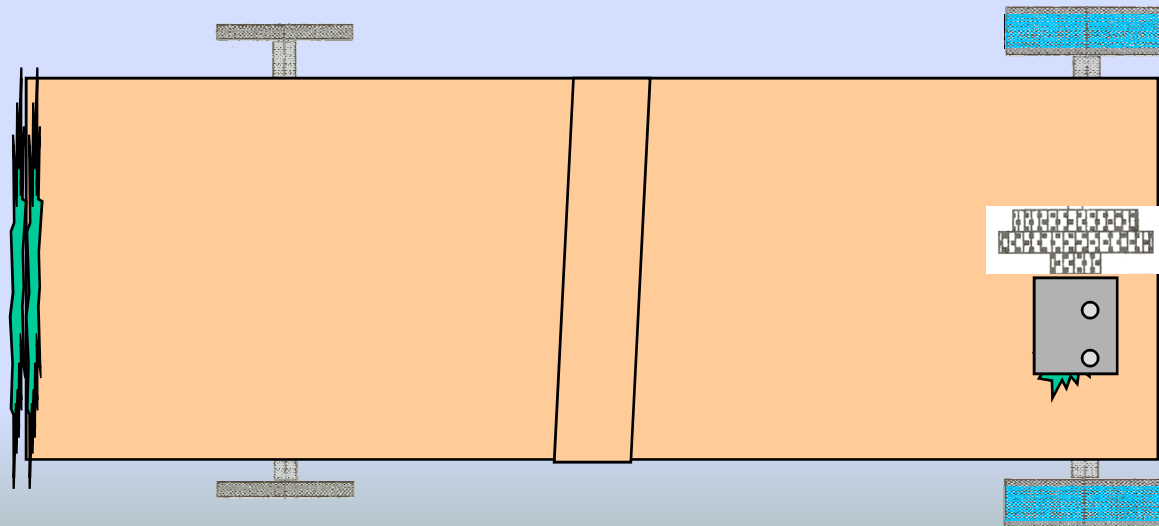

Final Assembly

Step 3

- Position the solar panel blank on the chassis so that it rests at the front of the vehicle and on the panel support member. The blank is used to show the position and effect of the solar panel on the vehicle while you test your vehicle with the battery pack. When you are ready to test or race, use the solar panel your teacher provides and replace the blank with the solar panel.

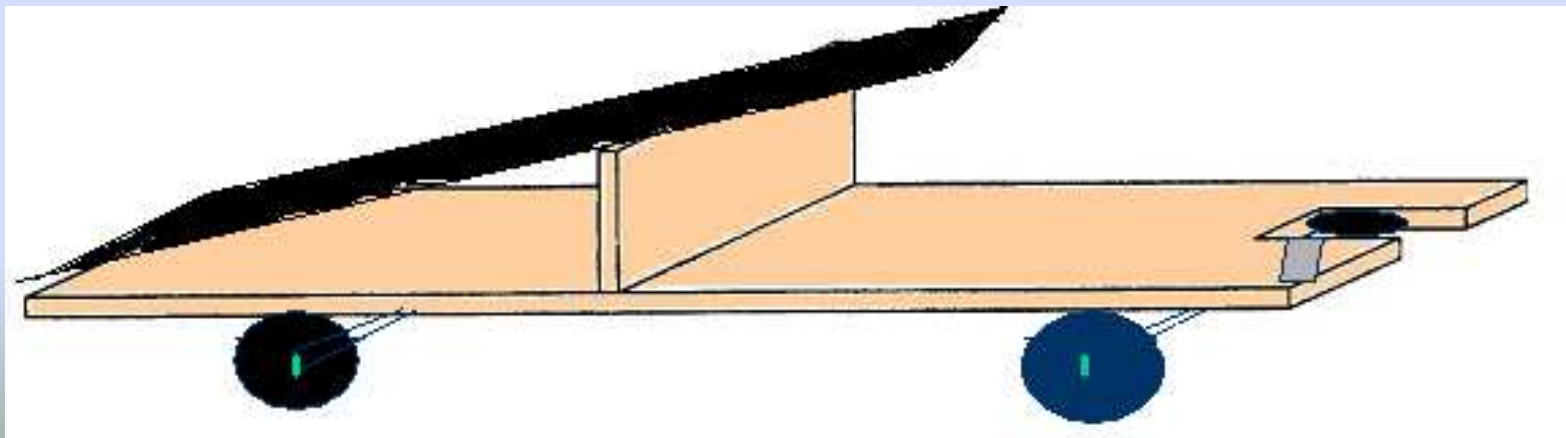

Final Assembly

Step 4

- Stretch one of the No. 14 rubber bands around the front of the chassis and the solar panel blank.

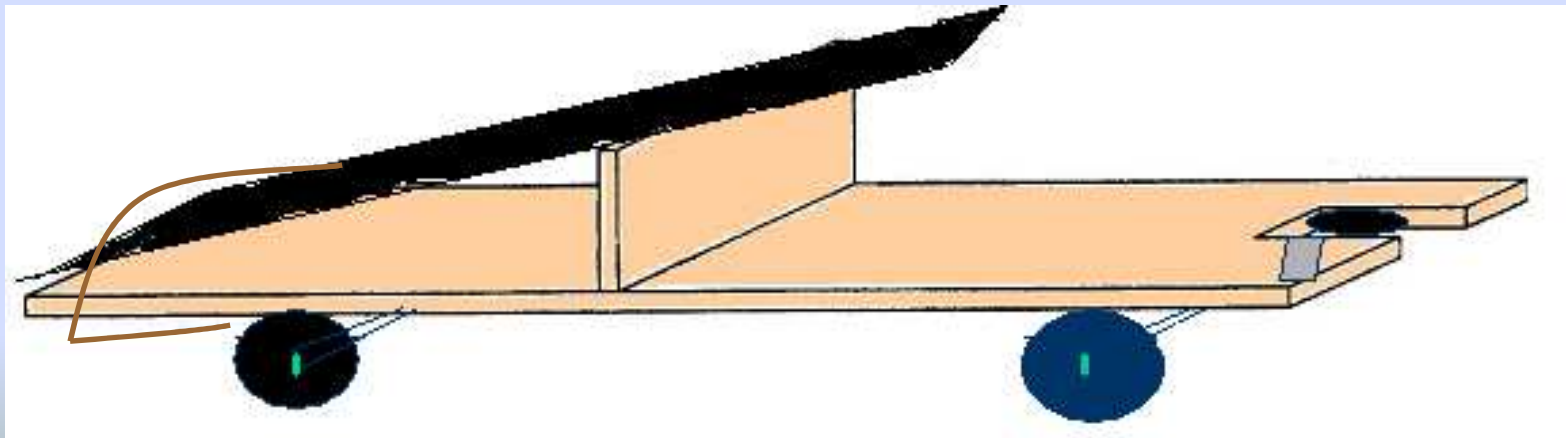

Final Assembly

Step 5

- Stretch the other No. 14 rubber band around the chassis and panel blank and position it at about the center of the panel blank.

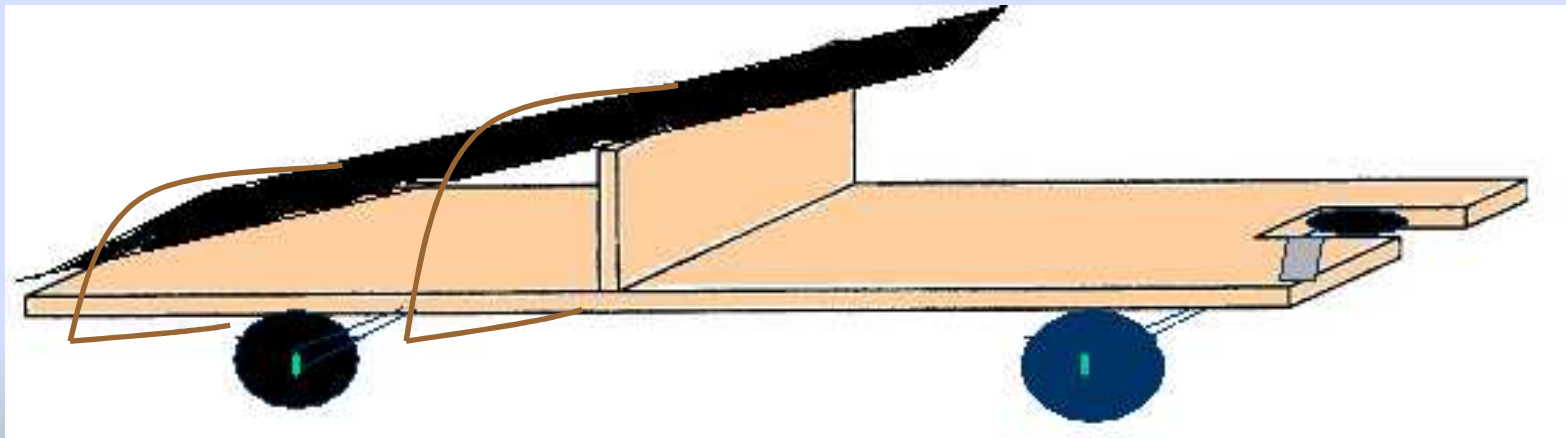

Final Assembly

Step 6

- Connect the battery pack alligator clip with the red lead to the motor terminal that has a round dot.

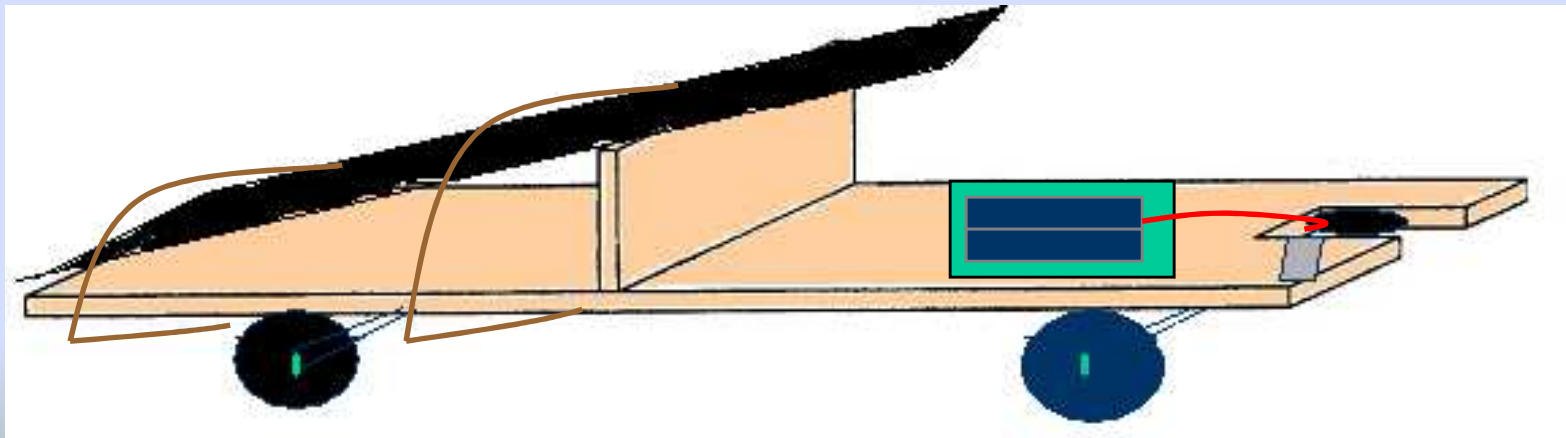

Congratulations!

You have completed a
Junior Solar Sprint car!

Troubleshooting

If the car does not go, check the following:

- Are all electric connections solid and soldered? If not, reconnect or solder and try again.
- Is the sun shining? If not, wait until the sun shines or use battery packs.
- Are the gears meshing freely? If not, pry the motor and glue from the chassis and reposition.
- If the car goes backward, reverse the positions of the two alligator clips on the panel.
- If the wheels do not spin freely, reposition them on the axles to provide clearance between the wheel and nylon sleeves.
- If the gears or wheels spin without the axle moving, use a spot of cool-melt glue at the joint to connect them. If you are sure of the position, you can use super glue to permanently bond them.
- If the car does not go fast enough, try different gear combinations, wheels, and chassis styles. Try to make a car with front-wheel drive! Experiment and find out what works best!!

http://www.nrel.gov/education/jss_hfc.html

Examples of JSS Cars



Examples of JSS Cars



Examples of JSS Cars



Examples of JSS Cars



Examples of JSS Cars



Examples of JSS Cars



Examples of JSS Cars



Examples of JSS Cars

